

WHAT'S AHEAD

1.1 The Study of Chemistry

We begin by providing a brief perspective of what chemistry is about and why it is useful to learn chemistry.

1.2 Classifications of Matter

Next, we examine some fundamental ways to classify materials, distinguishing between *pure substances* and *mixtures* and noting that there are two fundamentally different kinds of pure substances: *elements* and *compounds*.

1.3 Properties of Matter

We then consider some of the different kinds of characteristics, or *properties*, that we use to characterize, identify, and separate substances.

1.4 Units of Measurement

We observe that many properties rely on quantitative measurements, involving both

numbers and units. The units of measurement throughout science are those of the *metric system*, a decimal system of measurement.

1.5 Uncertainty in Measurement

We also observe that the uncertainties inherent in all measured quantities are expressed by the number of *significant figures* used to report the number. Significant figures are also used to express the uncertainties associated with calculations involving measured quantities.

1.6 Dimensional Analysis

We recognize that units as well as numbers are carried through calculations and that obtaining correct units for the result of a calculation is an important way to check whether the calculation is correct.

HAVE YOU EVER WONDERED why ice melts and water evaporates? Why do leaves turn colors in the fall, and how does a battery generate electricity? Why does keeping foods cold slow their spoilage, and how do our bodies use food to maintain life?

Chemistry answers these questions and countless others like them. **Chemistry** is the study of materials and the changes that materials undergo. One of the joys of learning chemistry is seeing how chemical principles operate in all aspects of our lives, from everyday activities like lighting a match to more far-reaching matters like the development of drugs to cure cancer. Chemical principles also operate in the far reaches of our galaxy (chapter-opening photo) as well as within and around us.

This first chapter lays a foundation for our study of chemistry by providing an overview of what chemistry is about and dealing with some fundamental concepts of matter and scientific measurements. The list above, entitled "What's Ahead," gives a brief overview of the organization of this chapter and some of the ideas that we will consider. As you study, keep in mind that the chemical facts and concepts you are asked to learn are not ends in themselves; they are tools to help you better understand the world around you.

1.1 THE STUDY OF CHEMISTRY

Before traveling to an unfamiliar city, you might look at a map to get some sense of where you are heading. Because chemistry may be unfamiliar to you, it's useful to get a general idea of what lies ahead before you embark on your journey. In fact, you might even ask why you are taking the trip.

The Atomic and Molecular Perspective of Chemistry

Chemistry is the study of the properties and behavior of matter. **Matter** is the physical material of the universe; it is anything that has mass and occupies space. A **property** is any characteristic that allows us to recognize a particular type of matter and to distinguish it from other types. This book, your body, the clothes you are wearing, and the air you are breathing are all samples of matter. Not all forms of matter are so common or so familiar. Countless experiments have shown that the tremendous variety of matter in our world is due to combinations of only about 100 very basic, or elementary, substances called **elements**. As we proceed through this text, we will seek to relate the properties of matter to its composition, that is, to the particular elements it contains.

Chemistry also provides a background to understanding the properties of matter in terms of **atoms**, the almost infinitesimally small building blocks of matter. Each element is composed of a unique kind of atom. We will see that the properties of matter relate to both the kinds of atoms the matter contains (*composition*) and to the arrangements of these atoms (*structure*).

Atoms can combine to form **molecules** in which two or more atoms are joined together in specific shapes. Throughout this text you will see molecules represented using colored spheres to show how their component atoms connect to each other (Figure 1.1 ▼). The color provides a convenient and easy way to distinguish between the atoms of different elements. For examples, compare the molecules of ethanol and ethylene glycol in Figure 1.1. Notice that these molecules have different compositions and structures. Ethanol contains only one oxygen atom, which is depicted by one red sphere. In contrast, ethylene glycol has two atoms of oxygen.

Even apparently minor differences in the composition or structure of molecules can cause profound differences in their properties. Ethanol, also called grain alcohol, is the alcohol in beverages such as beer and wine. Ethylene glycol, on the other hand, is a viscous liquid used as automobile antifreeze. The properties of these two substances differ in many ways, including the temperatures at which they freeze and boil. The biological activities of the two molecules are also quite different. Ethanol is consumed throughout the world, but

you should *never* consume ethylene glycol because it is highly toxic. One of the challenges that chemists undertake is to alter the composition or structure of molecules in a controlled way, creating new substances with different properties.

Every change in the observable world—from boiling water to the changes that occur as our bodies combat invading viruses—has its basis in the world of atoms and molecules. Thus, as we proceed with our study of chemistry, we will find ourselves thinking in two realms: the *macroscopic* realm

▼ **Figure 1.1 Molecular models.**
The white, dark gray, and red spheres represent atoms of hydrogen, carbon, and oxygen, respectively.

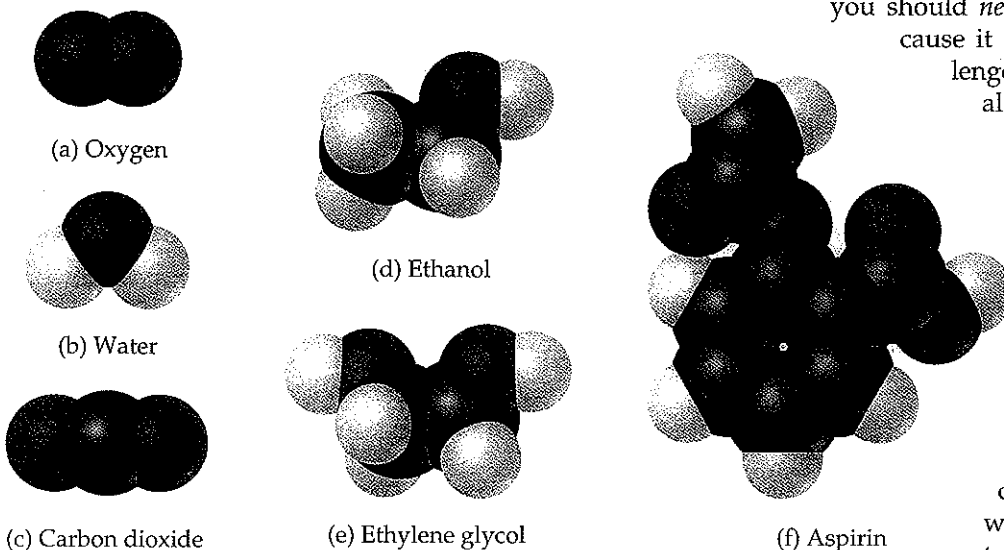

of ordinary-sized objects (*macro* = large) and the *submicroscopic* realm of atoms and molecules. We make our observations in the macroscopic world—in the laboratory and in our everyday surroundings. To understand that world, however, we must visualize how atoms and molecules behave at the submicroscopic level. Chemistry is the science that seeks to understand the properties and behavior of matter by studying the properties and behavior of atoms and molecules.

GIVE IT SOME THOUGHT

(a) In round numbers, about how many elements are there? (b) What submicroscopic particles are the building blocks of matter?

Why Study Chemistry?

Chemistry provides important understanding of our world and how it works. It is an extremely practical science that greatly impacts our daily lives. Indeed, chemistry lies near the heart of many matters of public concern: improvement of health care; conservation of natural resources; protection of the environment; and provision of our everyday needs for food, clothing, and shelter. Using chemistry, we have discovered pharmaceutical chemicals that enhance our health and prolong our lives. We have increased food production through the use of fertilizers and pesticides, and we have developed plastics and other materials that are used in almost every facet of our lives. Unfortunately, some chemicals also have the potential to harm our health or the environment. As educated citizens and consumers, it is in our best interest to understand the profound effects, both positive and negative, that chemicals have on our lives and to strike an informed balance about their uses.

Most of you are studying chemistry, however, not merely to satisfy your curiosity or to become more informed consumers or citizens, but because it is an essential part of your curriculum. Your major might be biology, engineering, pharmacy, agriculture, geology, or some other field. Why do so many diverse subjects share an essential tie to chemistry? The answer is that chemistry, by its very nature, is the *central science*, central to a fundamental understanding of other sciences and technologies. For example, our interactions with the material world raise basic questions about the materials around us. What are their compositions and properties? How do they interact with us and our environment? How, why, and when do they undergo change? These questions are important whether the material is part of high-tech computer chips, a pigment used by a Renaissance painter, or the DNA that transmits genetic information in our bodies (Figure 1.2 ▼).

By studying chemistry, you will learn to use the powerful language and ideas that have evolved to describe and enhance our understanding of matter. The language of chemistry is a universal scientific language that is widely used

▼ **Figure 1.2 Chemistry helps us better understand materials.** (a) A microscopic view of an EPROM (Erasable Programmable Read-Only Memory) silicon microchip. (b) A Renaissance painting, *Young Girl Reading*, by Vittore Carpaccio (1472–1526). (c) A long strand of DNA that has spilled out of the damaged cell wall of a bacterium.

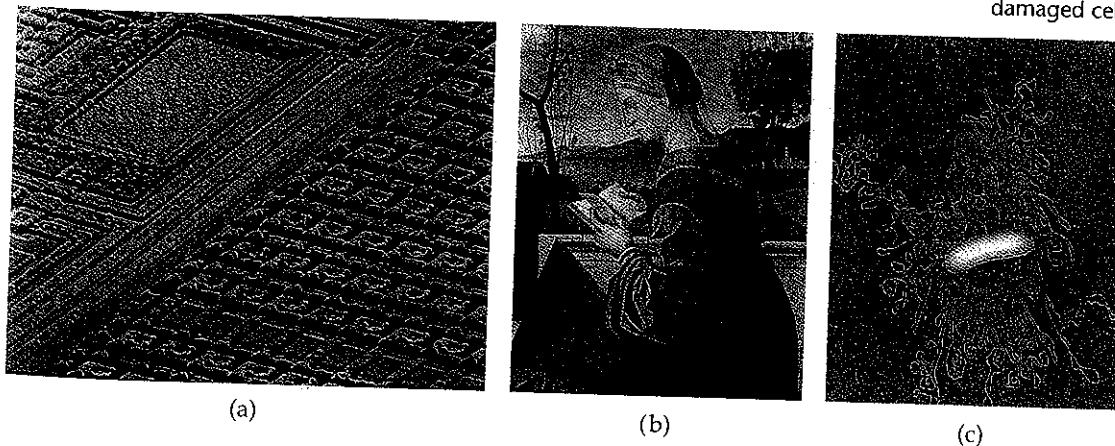

(a)

(b)

(c)

Chemistry Put to Work

CHEMISTRY AND THE CHEMICAL INDUSTRY

Many people are familiar with common household chemicals such as those shown in Figure 1.3, but few realize the size and importance of the chemical industry. Worldwide sales of chemicals and related products manufactured in the United States total approximately \$550 billion annually. The chemical industry employs more than 10% of all scientists and engineers and is a major contributor to the US economy.

Vast amounts of chemicals are produced each year and serve as raw materials for a variety of uses, including the manufacture of metals, plastics, fertilizers, pharmaceuticals, fuels, paints, adhesives, pesticides, synthetic fibers, microprocessor chips, and numerous other products. Table 1.1 lists the top eight chemicals produced in the United States. We will discuss many of these substances and their uses as the course progresses.

People who have degrees in chemistry hold a variety of positions in industry, government, and academia. Those who work in the chemical industry find positions as laboratory chemists, carrying out experiments to develop new products (research and development), analyzing materials (quality control), or assisting customers in using products (sales and service). Those with more experience or training may work as managers or company directors. A chemistry degree also can prepare you for alternate careers in teaching, medicine, biomedical research, information science, environmental work, technical sales, work with government regulatory agencies, and patent law.



▲ Figure 1.3 Household chemicals. Many common supermarket products have very simple chemical compositions.

TABLE 1.1 ■ The Top Eight Chemicals Produced by the Chemical Industry in 2006^a

| Rank | Chemical | Formula | 2006 Production (billions of pounds) | Principal End Uses |
|------|------------------|--------------------------------|---|--|
| 1 | Sulfuric acid | H ₂ SO ₄ | 79 | Fertilizers, chemical manufacturing |
| 2 | Ethylene | C ₂ H ₄ | 55 | Plastics, antifreeze |
| 3 | Lime | CaO | 45 | Paper, cement, steel |
| 4 | Propylene | C ₃ H ₆ | 35 | Plastics |
| 5 | Phosphoric acid | H ₃ PO ₄ | 24 | Fertilizers |
| 6 | Ammonia | NH ₃ | 23 | Fertilizers |
| 7 | Chlorine | Cl ₂ | 23 | Bleaches, plastics, water purification |
| 8 | Sodium hydroxide | NaOH | 18 | Aluminum production, soap |

^aMost data from *Chemical and Engineering News*, July 2, 2007, pp. 57, 60.

in other disciplines. Furthermore, an understanding of the behavior of atoms and molecules provides powerful insights into other areas of modern scientific technology, and engineering.

1.2 CLASSIFICATIONS OF MATTER

Let's begin our study of chemistry by examining some fundamental way in which matter is classified and described. Two principal ways of classifying matter are according to its physical state (as a gas, liquid, or solid) and according to its composition (as an element, compound, or mixture).

States of Matter

A sample of matter can be a gas, a liquid, or a solid. These three forms of matter are called the **states of matter**. The states of matter differ in some of their sin

observable properties. A **gas** (also known as *vapor*) has no fixed volume or shape; rather, it conforms to the volume and shape of its container. A gas can be compressed to occupy a smaller volume, or it can expand to occupy a larger one. A **liquid** has a distinct volume independent of its container but has no specific shape. A liquid assumes the shape of the portion of the container that it occupies. A **solid** has both a definite shape and a definite volume. Neither liquids nor solids can be compressed to any appreciable extent.

The properties of the states of matter can be understood on the molecular level (Figure 1.4▶). In a gas the molecules are far apart and are moving at high speeds, colliding repeatedly with each other and with the walls of the container. Compressing a gas decreases the amount of space between molecules, increases the frequency of collisions between molecules, but does not alter the size or shape of the molecules. In a liquid the molecules are packed closely together but still move rapidly. The rapid movement allows the molecules to slide over each other; thus, a liquid pours easily. In a solid the molecules are held tightly together, usually in definite arrangements in which the molecules can wiggle only slightly in their otherwise fixed positions.

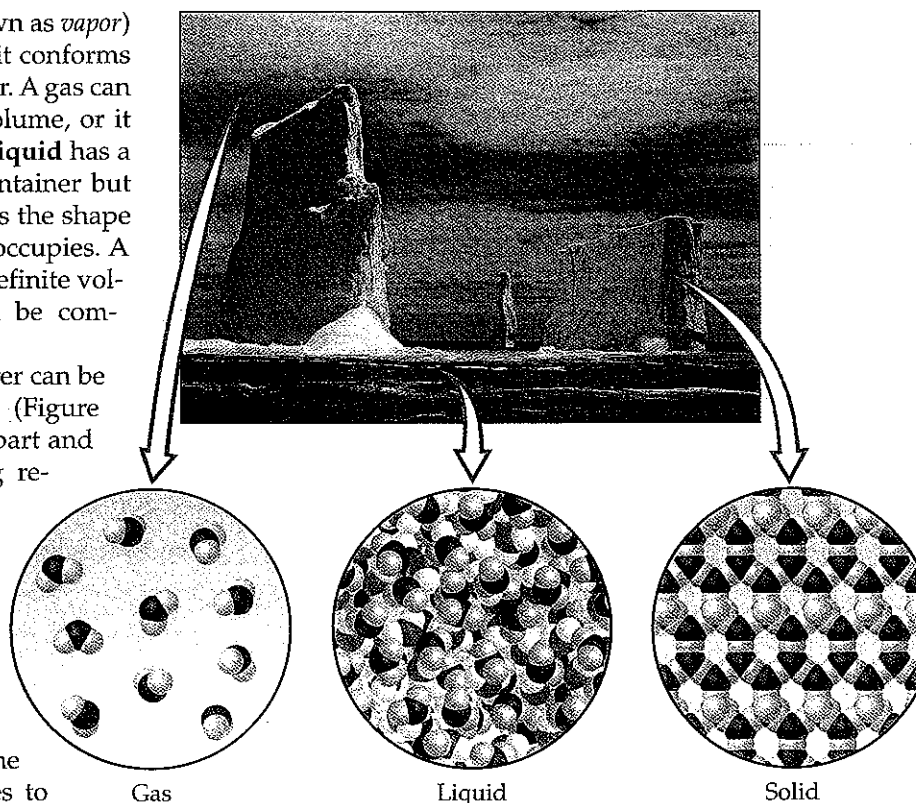

▲ **Figure 1.4 The three physical states of water—water vapor, liquid water, and ice.** In this photo we see both the liquid and solid states of water. We cannot see water vapor. What we see when we look at steam or clouds is tiny droplets of liquid water dispersed in the atmosphere. The molecular views show that the molecules in the gas are much further apart than those in the liquid or solid. The molecules in the liquid do not have the orderly arrangement seen in the solid.

Pure Substances

Most forms of matter that we encounter—for example, the air we breathe (a gas), gasoline for cars (a liquid), and the sidewalk on which we walk (a solid)—are not chemically pure. We can, however, resolve, or separate, these forms of matter into different pure substances. A **pure substance** (usually referred to simply as a *substance*) is matter that has distinct properties and a composition that does not vary from sample to sample. Water and ordinary table salt (sodium chloride), the primary components of seawater, are examples of pure substances.

All substances are either elements or compounds. **Elements** cannot be decomposed into simpler substances. On the molecular level, each element is composed of only one kind of atom [Figure 1.5(a and b)▼]. **Compounds** are

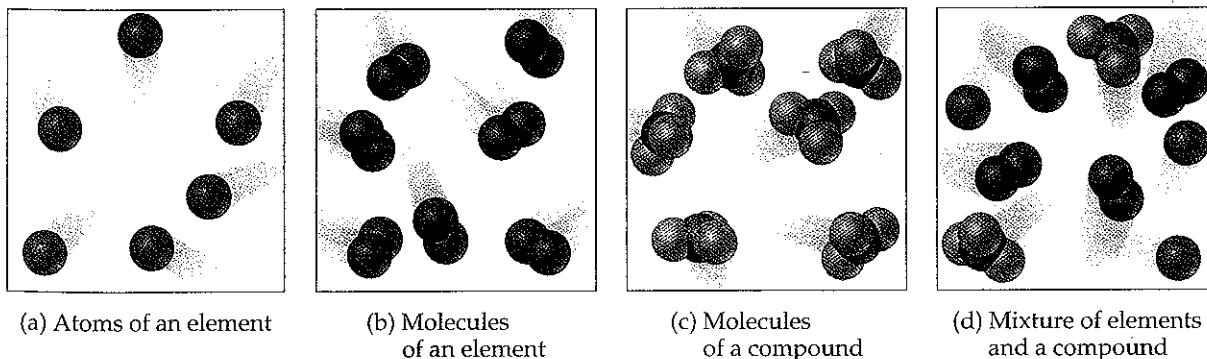

▲ **Figure 1.5 Molecular comparison of element, compounds, and mixtures.** Each element contains a unique kind of atom. Elements might consist of individual atoms, as in (a), or molecules, as in (b). Compounds contain two or more different atoms chemically joined together, as in (c). A mixture contains the individual units of its components, shown in (d) as both atoms and molecules.

► **Figure 1.6 Relative abundances of elements.** Elements in percent by mass in (a) Earth's crust (including oceans and atmosphere) and (b) the human body.

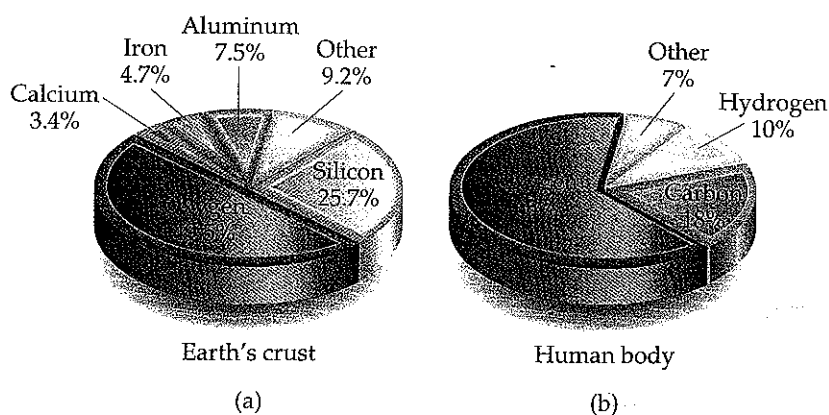

substances composed of two or more elements; they contain two or more kinds of atoms [Figure 1.5(c)]. Water, for example, is a compound composed of two elements: hydrogen and oxygen. Figure 1.5(d) shows a mixture of substances. Mixtures are combinations of two or more substances in which each substance retains its own chemical identity.

Elements

Currently, 117 elements are known. These elements vary widely in their abundance, as shown in Figure 1.6▲. For example, only five elements—oxygen, silicon, aluminum, iron, and calcium—account for over 90% of Earth's crust (including oceans and atmosphere). Similarly, just three elements—oxygen, carbon, and hydrogen—account for over 90% of the mass of the human body.

Some of the more common elements are listed in Table 1.2▼, along with their chemical abbreviations, or chemical *symbols*, used to denote them. The symbol for each element consists of one or two letters, with the first letter capitalized. These symbols are mostly derived from the English name for the element, but sometimes they are derived from a foreign name instead (last column in Table 1.2). You will need to know these symbols and learn others as we encounter them in the text.

All the known elements and their symbols are listed on the front inside cover of this text. The table in which the symbol for each element is enclosed in a box is called the *periodic table*. In the periodic table the elements are arranged in vertical columns so that closely related elements are grouped together. We describe the periodic table in more detail in Section 2.5.

GIVE IT SOME THOUGHT

Which element is most abundant in both Earth's crust and in the human body? What is the symbol for this element?

Compounds

Most elements can interact with other elements to form compounds. For example, consider the fact that when hydrogen gas burns in oxygen gas, the

TABLE 1.2 Some Common Elements and Their Symbols

| | | | | | |
|------------|---|-----------|----|-----------|-------------------------------|
| Carbon | C | Aluminum | Al | Copper | Cu (from <i>cuprum</i>) |
| Fluorine | F | Bromine | Br | Iron | Fe (from <i>ferrum</i>) |
| Hydrogen | H | Calcium | Ca | Lead | Pb (from <i>plumbum</i>) |
| Iodine | I | Chlorine | Cl | Mercury | Hg (from <i>hydrargyrum</i>) |
| Nitrogen | N | Helium | He | Potassium | K (from <i>kalium</i>) |
| Oxygen | O | Lithium | Li | Silver | Ag (from <i>argentum</i>) |
| Phosphorus | P | Magnesium | Mg | Sodium | Na (from <i>natrium</i>) |
| Sulfur | S | Silicon | Si | Tin | Sn (from <i>stannum</i>) |

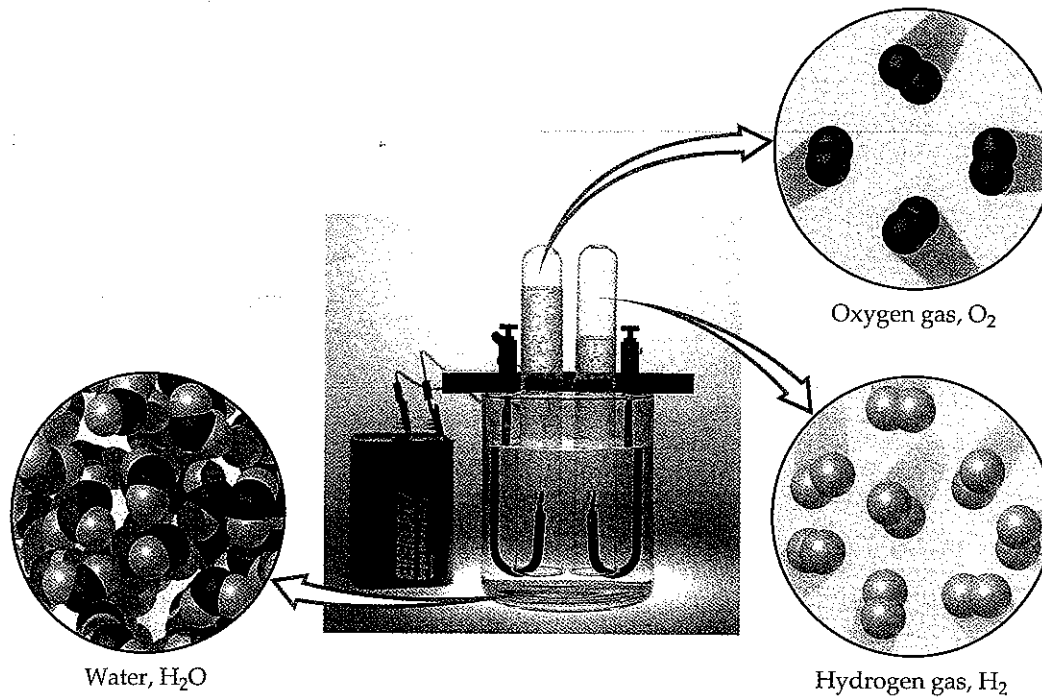

▲ **Figure 1.7 Electrolysis of water.** Water decomposes into its component elements, hydrogen and oxygen, when a direct electrical current is passed through it. The volume of hydrogen, which is collected in the right tube of the apparatus, is twice the volume of oxygen, which is collected in the left tube.

elements hydrogen and oxygen combine to form the compound water. Conversely, water can be decomposed into its component elements by passing an electrical current through it, as shown in Figure 1.7▲. Pure water, regardless of its source, consists of 11% hydrogen and 89% oxygen by mass. This macroscopic composition corresponds to the molecular composition, which consists of two hydrogen atoms combined with one oxygen atom:

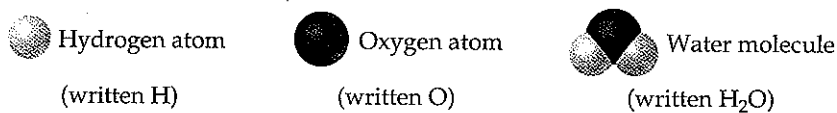

The elements hydrogen and oxygen themselves exist naturally as diatomic (two-atom) molecules:

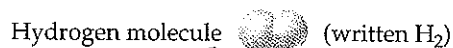

As seen in Table 1.3▼, the properties of water bear no resemblance to the properties of its component elements. Hydrogen, oxygen, and water are each a unique substance, a consequence of the uniqueness of their respective molecules.

TABLE 1.3 ◻ Comparison of Water, Hydrogen, and Oxygen

| | Water | Hydrogen | Oxygen |
|----------------------|----------|-----------|----------|
| State ^a | Liquid | Gas | Gas |
| Normal boiling point | 100 °C | -253 °C | -183 °C |
| Density ^a | 1000 g/L | 0.084 g/L | 1.33 g/L |
| Flammable | No | Yes | No |

^aAt room temperature and atmospheric pressure. (See Section 10.2.)

The observation that the elemental composition of a pure compound is always the same is known as the **law of constant composition** (or the **law of definite proportions**). French chemist Joseph Louis Proust (1754–1826) first put forth the law in about 1800. Although this law has been known for 200 years, the general belief persists among some people that a fundamental difference exists between compounds prepared in the laboratory and the corresponding compounds found in nature. However, a pure compound has the same composition and properties regardless of its source. Both chemists and nature must use the same elements and operate under the same natural laws. When two materials differ in composition and properties, we know that they are composed of different compounds or that they differ in purity.

GIVE IT SOME THOUGHT

Hydrogen, oxygen, and water are all composed of molecules. What is it about a molecule of water that makes it a compound, whereas hydrogen and oxygen are elements?

Mixtures

Most of the matter we encounter consists of mixtures of different substances. Each substance in a mixture retains its own chemical identity and its own properties. In contrast to a pure substance that has a fixed composition, the composition of a mixture can vary. A cup of sweetened coffee, for example, can contain either a little sugar or a lot. The substances making up a mixture (such as sugar and water) are called *components* of the mixture.

Some mixtures do not have the same composition, properties, and appearance throughout. Both rocks and wood, for example, vary in texture and appearance throughout any typical sample. Such mixtures are *heterogeneous*. [Figure 1.8(a) ▼]. Mixtures that are uniform throughout are *homogeneous*. Air is a homogeneous mixture of the gaseous substances nitrogen, oxygen, and smaller amounts of other substances. The nitrogen in air has all the properties that pure nitrogen does because both the pure substance and the mixture contain the same nitrogen molecules. Salt, sugar, and many other substances dissolve in water to form homogeneous mixtures [Figure 1.8(b)]. Homogeneous mixtures are also called **solutions**. Although the term solution conjures an image of a liquid in a beaker or flask, solutions can be solids, liquids, or gases. Figure 1.9 ► summarizes the classification of matter into elements, compounds, and mixtures.

► **Figure 1.8 Mixtures.** (a) Many common materials, including rocks, are heterogeneous. This close-up photo is of malachite, a copper mineral. (b) Homogeneous mixtures are called solutions. Many substances, including the blue solid shown in this photo (copper sulfate), dissolve in water to form solutions.

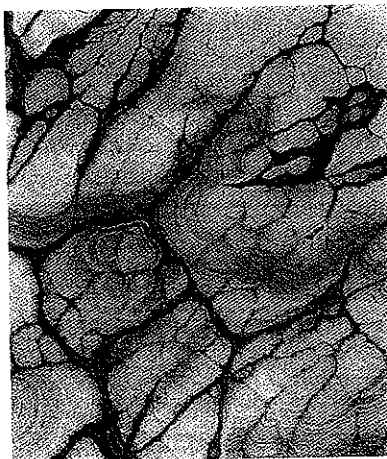

(a)



(b)

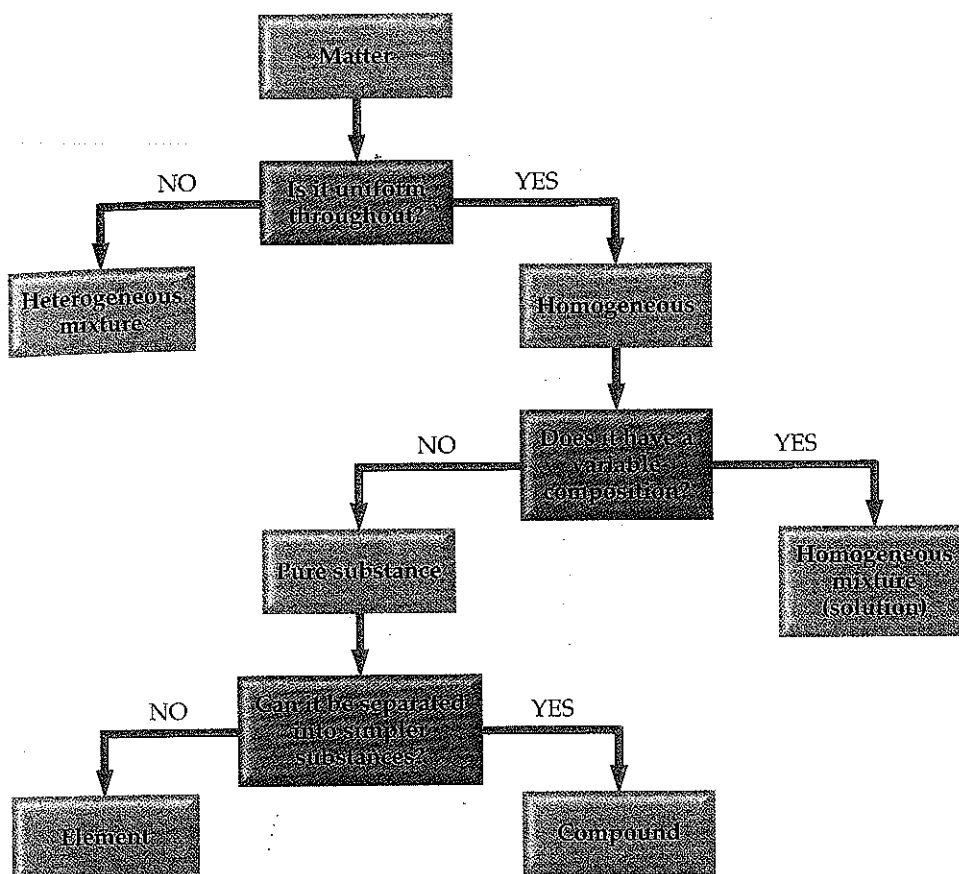

◀ **Figure 1.9 Classification of matter.** At the chemical level all matter is classified ultimately as either elements or compounds.

■ SAMPLE EXERCISE 1.1 | Distinguishing Among Elements, Compounds, and Mixtures

"White gold," used in jewelry, contains gold and another "white" metal such as palladium. Two different samples of white gold differ in the relative amounts of gold and palladium that they contain. Both samples are uniform in composition throughout. Without knowing any more about the materials, use Figure 1.9 to classify white gold.

SOLUTION

Because the material is uniform throughout, it is homogeneous. Because its composition differs for the two samples, it cannot be a compound. Instead, it must be a homogeneous mixture.

■ PRACTICE EXERCISE

Aspirin is composed of 60.0% carbon, 4.5% hydrogen, and 35.5% oxygen by mass, regardless of its source. Use Figure 1.9 to characterize and classify aspirin.

Answer: It is a compound because it has constant composition and can be separated into several elements.

1.3 PROPERTIES OF MATTER

Every substance has a unique set of properties. For example, the properties listed in Table 1.3 allow us to distinguish hydrogen, oxygen, and water from one another. The properties of matter can be categorized as physical or chemical. **Physical properties** can be observed without changing the identity and composition of the substance. These properties include color, odor, density, melting point, boiling point, and hardness. **Chemical properties** describe the way a substance may change, or *react*, to form other substances. A common chemical property is flammability, the ability of a substance to burn in the presence of oxygen.

Some properties, such as temperature, melting point, and density, are called **intensive properties**. They do not depend on the amount of the sample being examined and are particularly useful in chemistry because many of these properties can be used to *identify* substances. **Extensive properties** of substances depend on the quantity of the sample, with two examples being mass and volume. Extensive properties relate to the *amount* of substance present.

Physical and Chemical Changes

As with the properties of a substance, the changes that substances undergo can be classified as either physical or chemical. During a **physical change** a substance changes its physical appearance but not its composition. (That is, it is the same substance before and after the change.) The evaporation of water is a physical change. When water evaporates, it changes from the liquid state to the gas state, but it is still composed of water molecules, as depicted earlier in Figure 1.4. All **changes of state** (for example, from liquid to gas or from liquid to solid) are physical changes.

In a **chemical change** (also called a **chemical reaction**) a substance is transformed into a chemically different substance. When hydrogen burns in air, for example, it undergoes a chemical change because it combines with oxygen to form water. The molecular-level view of this process is depicted in Figure 1.10.

Chemical changes can be dramatic. In the account that follows, Ira Renshaw, author of a popular chemistry text published in 1901, describes his first

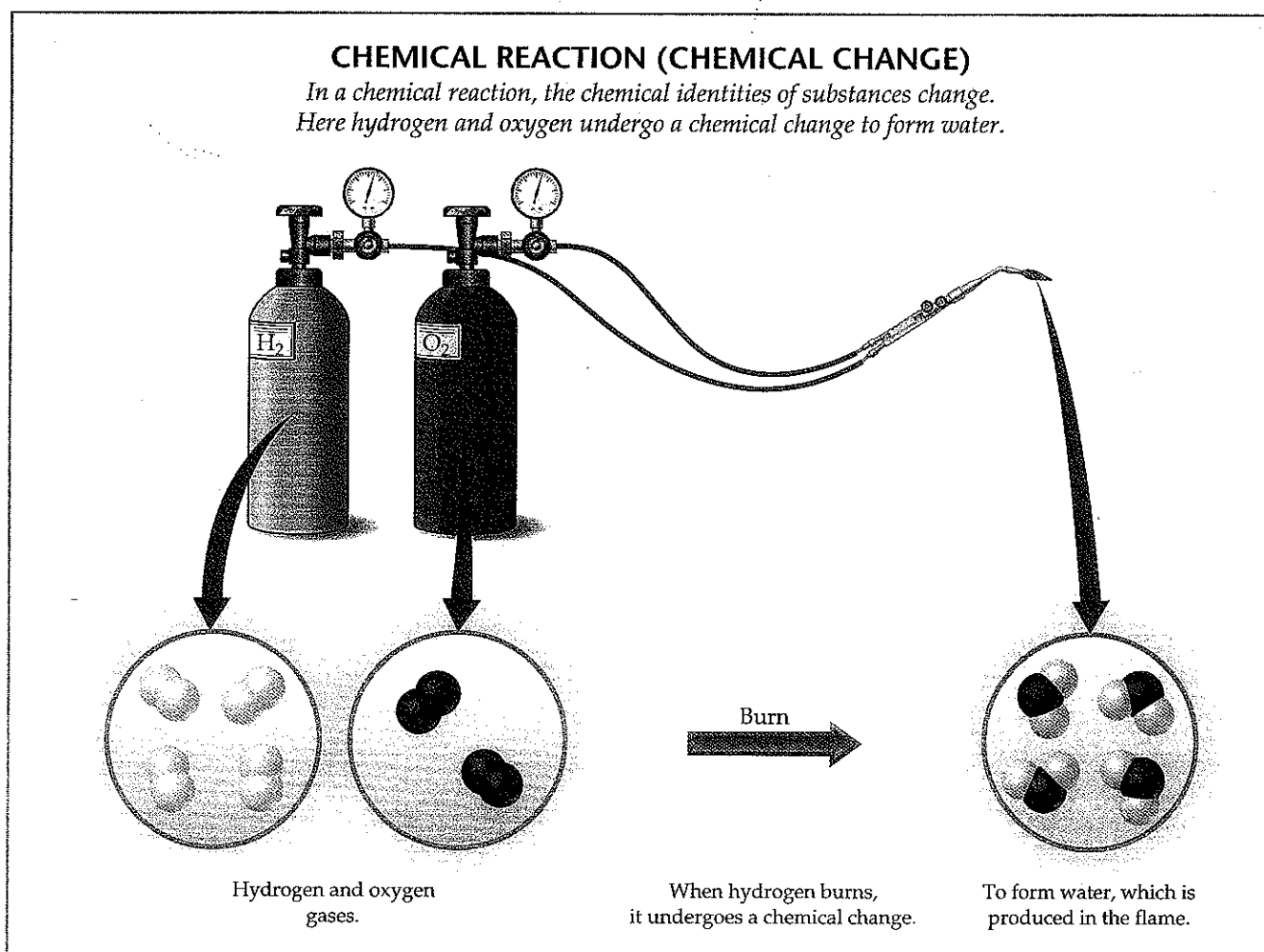

▲ Figure 1.10 A chemical reaction.

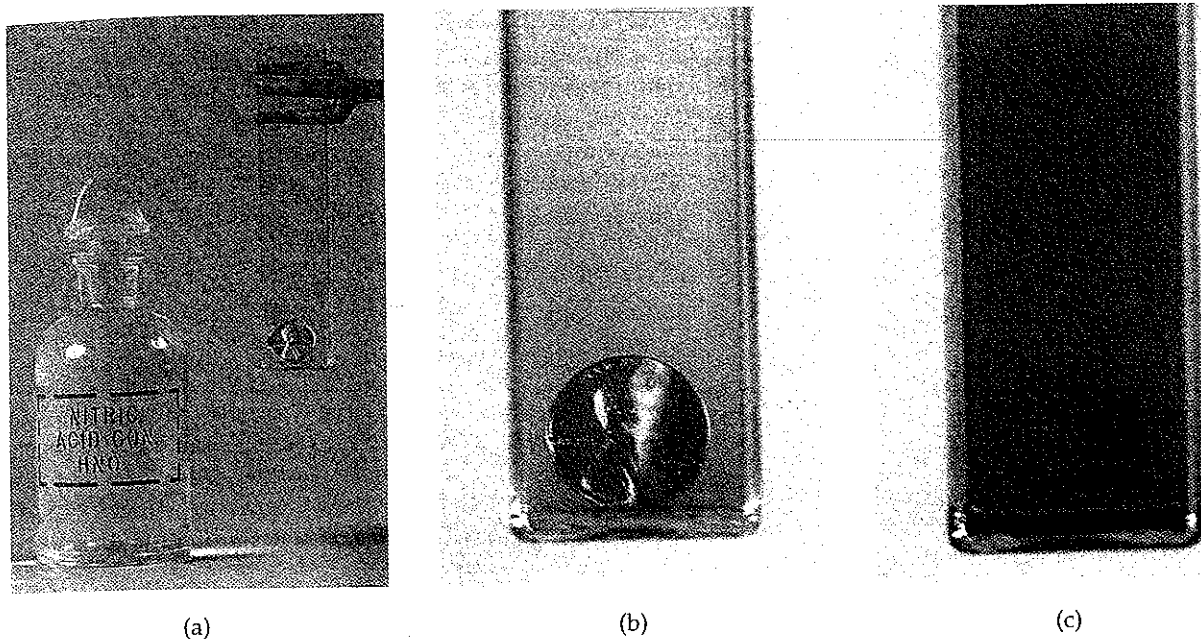

▲ Figure 1.11 The chemical reaction between a copper penny and nitric acid. The dissolved copper produces the blue-green solution; the reddish brown gas produced is nitrogen dioxide.

experiences with chemical reactions. The chemical reaction that he observed is shown in Figure 1.11 ▲.

While reading a textbook of chemistry, I came upon the statement “nitric acid acts upon copper,” and I determined to see what this meant. Having located some nitric acid, I had only to learn what the words “act upon” meant. In the interest of knowledge I was even willing to sacrifice one of the few copper cents then in my possession. I put one of them on the table, opened a bottle labeled “nitric acid,” poured some of the liquid on the copper, and prepared to make an observation. But what was this wonderful thing which I beheld? The cent was already changed, and it was no small change either. A greenish-blue liquid foamed and fumed over the cent and over the table. The air became colored dark red. How could I stop this? I tried by picking the cent up and throwing it out the window. I learned another fact: nitric acid acts upon fingers. The pain led to another unpremeditated experiment. I drew my fingers across my trousers and discovered nitric acid acts upon trousers. That was the most impressive experiment I have ever performed. I tell of it even now with interest. It was a revelation to me. Plainly the only way to learn about such remarkable kinds of action is to see the results, to experiment, to work in the laboratory.

GIVE IT SOME THOUGHT

Which of the following is a physical change, and which is a chemical change? Explain.
 (a) Plants use carbon dioxide and water to make sugar. (b) Water vapor in the air on a cold day forms frost.

Separation of Mixtures

Because each component of a mixture retains its own properties, we can separate a mixture into its components by taking advantage of the differences in their properties. For example, a heterogeneous mixture of iron filings and gold filings could be sorted individually by color into iron and gold. A less tedious approach would be to use a magnet to attract the iron filings, leaving the gold ones behind. We can also take advantage of an important chemical difference between these two metals: Many acids dissolve iron but not gold. Thus, if we put our mixture into an appropriate acid, the acid would dissolve the iron and the gold would be left behind. The two could then be separated by *filtration*, a

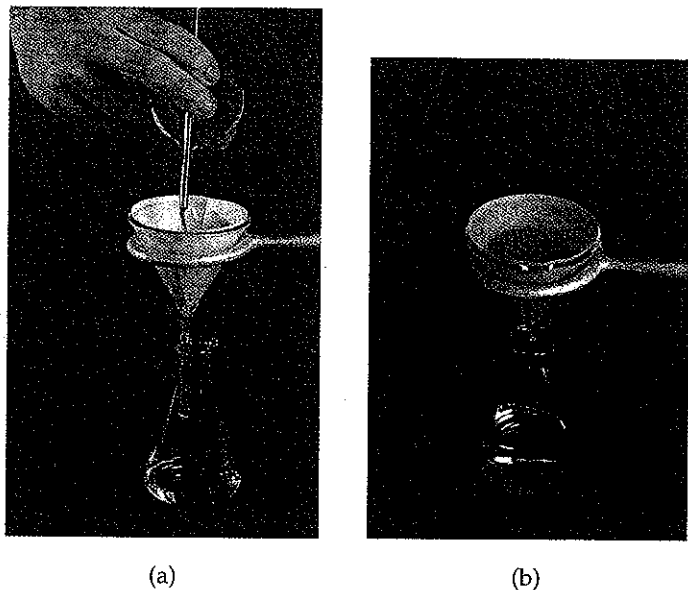

▲ **Figure 1.12 Separation by filtration.** A mixture of a solid and a liquid is poured through a porous medium, in this case filter paper. The liquid passes through the paper while the solid remains on the paper.

procedure illustrated in Figure 1.12 ◀. We would have to use other chemical reactions, which we will learn about later, to transform the dissolved iron back into metal.

An important method of separating the components of a homogeneous mixture is *distillation*, a process that depends on the different abilities of substances to form gases. For example, if we boil a solution of salt and water, the water evaporates, forming a gas, and the salt is left behind. The gaseous water can be converted back to a liquid on the walls of a condenser, as shown in the apparatus depicted in Figure 1.13 ▼.

The differing abilities of substances to adhere to the surfaces of various solids such as paper and starch can also be used to separate mixtures. This ability is the basis of *chromatography* (literally “the writing of colors”), a technique that can give beautiful and dramatic results. An example of the chromatographic separation of ink is shown in Figure 1.14 ▼.

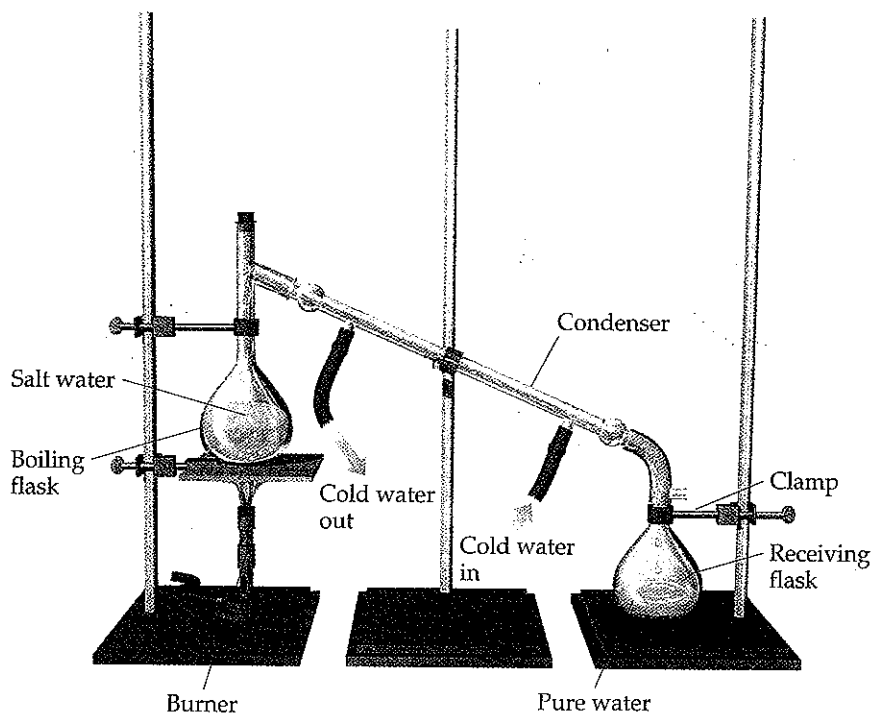

► **Figure 1.13 Distillation.** A simple apparatus for the separation of a sodium chloride solution (salt water) into its components. Boiling the solution vaporizes the water, which is condensed, then collected in the receiving flask. After all the water has boiled away, pure sodium chloride remains in the boiling flask.

► **Figure 1.14 Separation of ink into components by paper chromatography.**

(a) Water begins to move up the paper. (b) Water moves past the ink spot, dissolving different components of the ink at different rates. (c) The ink has separated into its several different components.

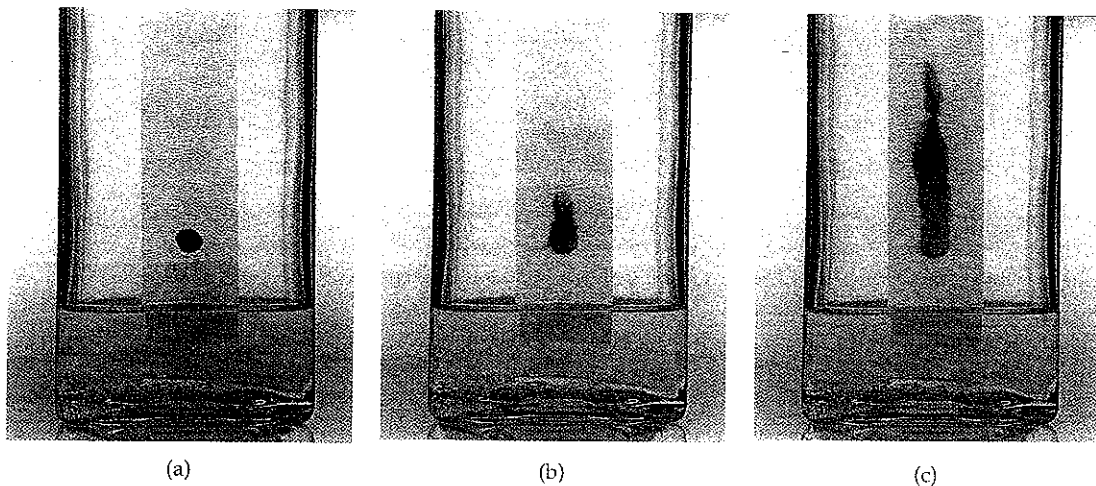

A Closer Look THE SCIENTIFIC METHOD

Although two scientists rarely approach the same problem in exactly the same way, they use guidelines for the practice of science that are known as the **scientific method**. These guidelines are outlined in Figure 1.15 ▼. We begin our study by collecting information, or *data*, by observation and experiment. The collection of information, however, is not the ultimate goal. The goal is to find a pattern or sense of order in our observations and to understand the origin of this order.

As we perform our experiments, we may begin to see patterns that lead us to a *tentative explanation*, or **hypothesis**, that guides us in planning further experiments. Eventually, we may be able to tie together a great number of observations in a single statement or equation called a scientific law. A **scientific law** is a concise verbal statement or a mathematical equation that summarizes a broad variety of observations and experiences. We tend to think of the laws of nature as the basic rules under which nature operates. However, it is not so much that matter obeys the laws of nature, but rather that the laws of nature describe the behavior of matter.

At many stages of our studies we may propose explanations of why nature behaves in a particular way. If a hypothesis is sufficiently general and is continually effective in predicting facts yet to be observed, it is called a theory. A **theory** is an explanation of the general causes of certain phenomena, with considerable

evidence or facts to support it. For example, Einstein's theory of relativity was a revolutionary new way of thinking about space and time. It was more than just a simple hypothesis, however, because it could be used to make predictions that could be tested experimentally. When these experiments were conducted, the results were generally in agreement with the predictions and were not explainable by earlier theories. Thus, the theory of relativity was supported, but not proven. Indeed, theories can never be proven to be absolutely correct.

As we proceed through this text, we will rarely have the opportunity to discuss the doubts, conflicts, clashes of personalities, and revolutions of perception that have led to our present ideas. We need to be aware that just because we can spell out the results of science so concisely and neatly in textbooks it does not mean that scientific progress is smooth, certain and predictable. Some of the ideas we present in this text took centuries to develop and involved many scientists. We gain our view of the natural world by standing on the shoulders of the scientists who came before us. Take advantage of this view. As you study, exercise your imagination. Don't be afraid to ask daring questions when they occur to you. You may be fascinated by what you discover!

Related Exercise: 1.57

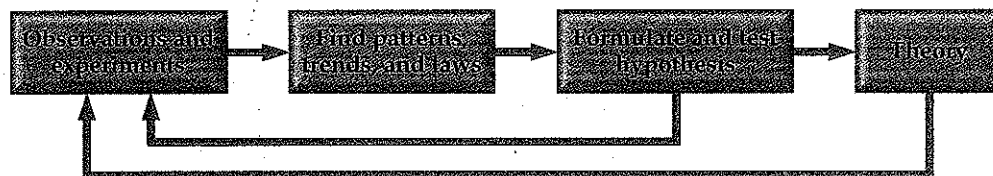

▲ **Figure 1.15 The scientific method.** The scientific method is a general approach to solving problems that involves making observations, seeking patterns in the observations, formulating hypotheses to explain the observations, and testing these hypotheses by further experiments. Those hypotheses that withstand such tests and prove themselves useful in explaining and predicting behavior become known as theories.

1.4 UNITS OF MEASUREMENT

Many properties of matter are *quantitative*; that is, they are associated with numbers. When a number represents a measured quantity, the units of that quantity must always be specified. To say that the length of a pencil is 17.5 is meaningless. Expressing the number with its units, 17.5 centimeters (cm), properly specifies the length. The units used for scientific measurements are those of the **metric system**.

The metric system, which was first developed in France during the late eighteenth century, is used as the system of measurement in most countries throughout the world. The United States has traditionally used the English system, although use of the metric system has become more common. For example, the contents of most canned goods and soft drinks in grocery stores are now given in metric as well as in English units, as shown in Figure 1.16 ►.

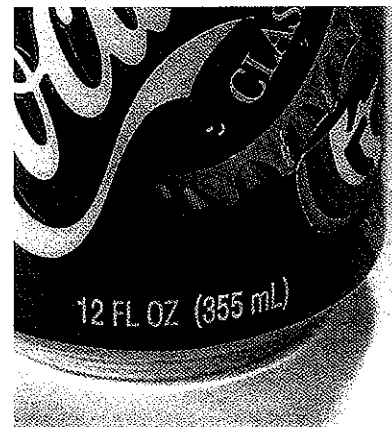

▲ **Figure 1.16 Metric units.** Metric measurements are increasingly common in the United States, as exemplified by the volume printed on this soda can.

SI Units

In 1960 an international agreement was reached specifying a particular choice of metric units for use in scientific measurements. These preferred units are

TABLE 1.4 ■ SI Base Units

| Physical Quantity | Name of Unit | Abbreviation |
|---------------------|--------------|----------------|
| Mass | Kilogram | kg |
| Length | Meter | m |
| Time | Second | s ^a |
| Temperature | Kelvin | K |
| Amount of substance | Mole | mol |
| Electric current | Ampere | A |
| Luminous intensity | Candela | cd |

^aThe abbreviation sec is frequently used.

called **SI units**, after the French *Système International d'Unités*. This system has seven *base units* from which all other units are derived. Table 1.4▲ lists these base units and their symbols. In this chapter we will consider the base units for length, mass, and temperature.

In the metric system, prefixes are used to indicate decimal fractions or multiples of various units. For example, the prefix *milli-* represents a 10^{-3} fraction of a unit: A milligram (mg) is 10^{-3} gram (g), a millimeter (mm) is 10^{-3} meter (m), and so forth. Table 1.5▼ presents the prefixes commonly encountered in chemistry. In using SI units and in working problems throughout this text, you must be comfortable using exponential notation. If you are unfamiliar with exponential notation or want to review it, refer to Appendix A.1.

Although non-SI units are being phased out, some are still commonly used by scientists. Whenever we first encounter a non-SI unit in the text, the proper SI unit will also be given.

TABLE 1.5 ■ Selected Prefixes Used in the Metric System

| Prefix | Abbreviation | Meaning | Example |
|--------|--------------|------------|---|
| Giga | G | 10^9 | 1 gigameter (Gm) = 1×10^9 m |
| Mega | M | 10^6 | 1 megameter (Mm) = 1×10^6 m |
| Kilo | k | 10^3 | 1 kilometer (km) = 1×10^3 m |
| Deci | d | 10^{-1} | 1 decimeter (dm) = 0.1 m |
| Centi | c | 10^{-2} | 1 centimeter (cm) = 0.01 m |
| Milli | m | 10^{-3} | 1 millimeter (mm) = 0.001 m |
| Micro | μ^a | 10^{-6} | 1 micrometer (μm) = 1×10^{-6} m |
| Nano | n | 10^{-9} | 1 nanometer (nm) = 1×10^{-9} m |
| Pico | p | 10^{-12} | 1 picometer (pm) = 1×10^{-12} m |
| Femto | f | 10^{-15} | 1 femtometer (fm) = 1×10^{-15} m |

^aThis is the Greek letter mu (pronounced "mew").

GIVE IT SOME THOUGHT

Which of the following quantities is the smallest: 1 mg, $1\mu\text{g}$, or 1 pg?

Length and Mass

The SI base unit of *length* is the meter (m), a distance only slightly longer than a yard. The relations between the English and metric system units that we will use most frequently in this text appear on the back inside cover. We will discuss how to convert English units into metric units, and vice versa, in Section 1.6.

Mass* is a measure of the amount of material in an object. The SI base unit of mass is the kilogram (kg), which is equal to about 2.2 pounds (lb). This base unit is unusual because it uses a prefix, *kilo-*, instead of the word *gram* alone. We obtain other units for mass by adding prefixes to the word *gram*.

SAMPLE EXERCISE 1.2 | Using Metric Prefixes

What is the name given to the unit that equals (a) 10^{-9} gram, (b) 10^{-6} second, (c) 10^{-3} meter?

SOLUTION

In each case we can refer to Table 1.5, finding the prefix related to each of the decimal fractions: (a) nanogram, ng, (b) microsecond, μ s, (c) millimeter, mm.

PRACTICE EXERCISE

(a) What decimal fraction of a second is a picosecond, ps? (b) Express the measurement 6.0×10^3 m using a prefix to replace the power of ten. (c) Use exponential notation to express 3.76 mg in grams.

Answers: (a) 10^{-12} second, (b) 6.0 km, (c) 3.76×10^{-3} g

Temperature

Temperature is a measure of the hotness or coldness of an object. Indeed, temperature is a physical property that determines the direction of heat flow. Heat always flows spontaneously from a substance at higher temperature to one at lower temperature. Thus, we feel the influx of heat when we touch a hot object, and we know that the object is at a higher temperature than our hand.

The temperature scales commonly employed in scientific studies are the Celsius and Kelvin scales. The **Celsius scale** is also the everyday scale of temperature in most countries (Figure 1.17▶). It was originally based on the assignment of 0 °C to the freezing point of water and 100 °C to its boiling point at sea level (Figure 1.18▼).

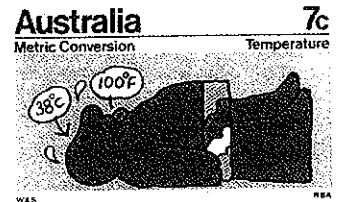

▲ **Figure 1.17 Australian stamp.** Many countries employ the Celsius temperature scale in everyday use, as illustrated by this stamp.

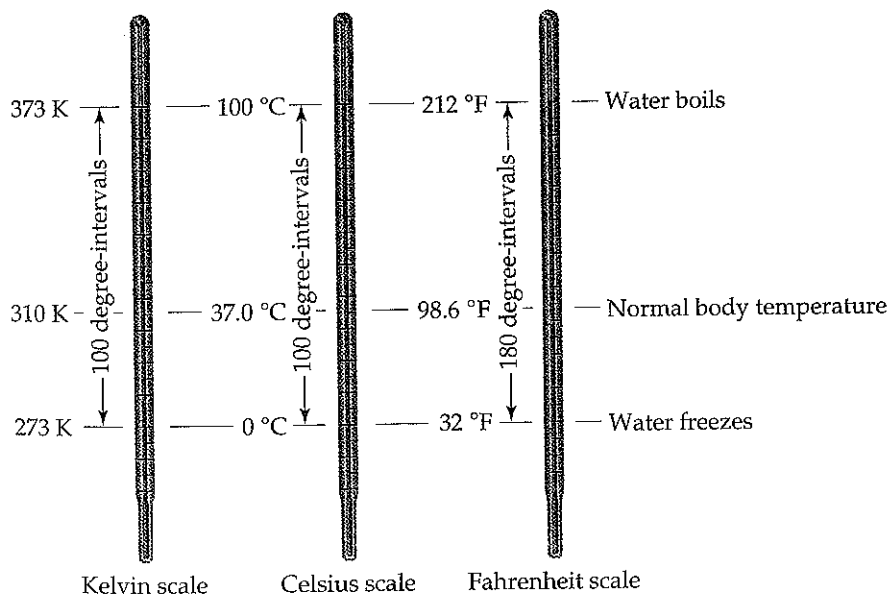

◀ **Figure 1.18 Comparison of the Kelvin, Celsius, and Fahrenheit temperature scales.** The freezing point and boiling point of water as well as normal human body temperature is indicated on each of the scales.

*Mass and weight are not interchangeable terms but are often incorrectly thought to be the same. The weight of an object is the force that its mass exerts due to gravity. In space, where gravitational forces are very weak, an astronaut can be weightless, but he or she cannot be massless. In fact, the astronaut's mass in space is the same as it is on Earth.

The **Kelvin scale** is the SI temperature scale, and the SI unit of temperature is the kelvin (K). Historically, the Kelvin scale was based on the properties of gases; its origins will be considered in Chapter 10. Zero on this scale is the lowest attainable temperature, $-273.15\text{ }^{\circ}\text{C}$, a temperature referred to as *absolute zero*. Both the Celsius and Kelvin scales have equal-sized units—that is, a kelvin is the same size as a degree Celsius. Thus, the Kelvin and Celsius scales are related as follows:

$$\text{K} = ^{\circ}\text{C} + 273.15 \quad [1]$$

The freezing point of water, $0\text{ }^{\circ}\text{C}$, is 273.15 K (Figure 1.18). Notice that we do not use a degree sign ($^{\circ}$) with temperatures on the Kelvin scale.

The common temperature scale in the United States is the *Fahrenheit scale*, which is not generally used in scientific studies. On the Fahrenheit scale, water freezes at $32\text{ }^{\circ}\text{F}$ and boils at $212\text{ }^{\circ}\text{F}$. The Fahrenheit and Celsius scales are related as follows:

$$^{\circ}\text{C} = \frac{5}{9} (^{\circ}\text{F} - 32) \quad \text{or} \quad ^{\circ}\text{F} = \frac{9}{5} (^{\circ}\text{C}) + 32 \quad [1]$$

■ SAMPLE EXERCISE 1.3 | Converting Units of Temperature

If a weather forecaster predicts that the temperature for the day will reach $31\text{ }^{\circ}\text{C}$, what is the predicted temperature (a) in K, (b) in $^{\circ}\text{F}$?

SOLUTION

(a) Using Equation 1.1, we have $\text{K} = 31 + 273 = 304\text{ K}$

(b) Using Equation 1.2, we have $^{\circ}\text{F} = \frac{9}{5}(31) + 32 = 56 + 32 = 88\text{ }^{\circ}\text{F}$

■ PRACTICE EXERCISE

Ethylene glycol, the major ingredient in antifreeze, freezes at $-11.5\text{ }^{\circ}\text{C}$. What is the freezing point in (a) K, (b) $^{\circ}\text{F}$?

Answers: (a) 261.7 K , (b) $11.3\text{ }^{\circ}\text{F}$

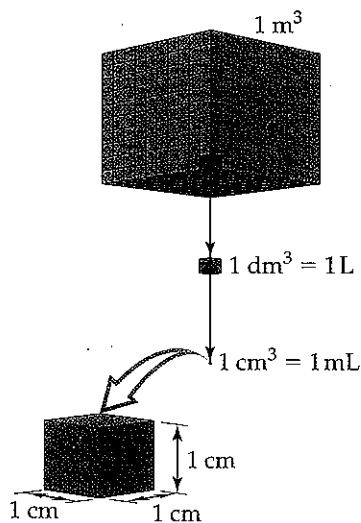

▲ **Figure 1.19 Volume relationships.** The volume occupied by a cube that is 1 m on each edge is a cubic meter, 1 m^3 (top). Each cubic meter contains 1000 dm^3 (middle). A liter is the same volume as a cubic decimeter, $1\text{ L} = 1\text{ dm}^3$. Each cubic decimeter contains 1000 cubic centimeters, $1\text{ dm}^3 = 1000\text{ cm}^3$. Each cubic centimeter equals 1 milliliter, $1\text{ cm}^3 = 1\text{ mL}$ (bottom).

Derived SI Units

The SI base units in Table 1.4 are used to derive the units of other quantities. To do so, we use the defining equation for the quantity, substituting the appropriate base units. For example, speed is defined as the ratio of distance traveled to elapsed time. Thus, the SI unit for speed— m/s , which we read as “meters per second”—is the SI unit for distance (length), m , divided by the SI unit for time, s . We will encounter many derived units, such as those for force, pressure, and energy, later in this text. In this chapter we examine the derived units for volume and density.

Volume

The *volume* of a cube is given by its length cubed, $(\text{length})^3$. Thus, the SI unit for volume is the SI unit of length, m , raised to the third power. The cubic meter, m^3 , is the volume of a cube that is 1 m on each edge. Smaller units, such as cubic centimeters, cm^3 (sometimes written as cc), are frequently used in chemistry. Another unit of volume commonly used in chemistry is the *liter* (L), which equals a cubic decimeter, dm^3 , and is slightly larger than a quart. The liter is the first metric unit we have encountered that is *not* an SI unit. There are 1000 milliliters (mL) in a liter (Figure 1.19), and each milliliter is the same volume as a cubic centimeter: $1\text{ mL} = 1\text{ cm}^3$. The terms *milliliter* and *cubic centimeter* are used interchangeably in expressing volume.

The devices used most frequently in chemistry to measure volume are illustrated in Figure 1.20. Syringes, burets, and pipets deliver liquids with more precision than graduated cylinders. Volumetric flasks are used to contain specific volumes of liquid.

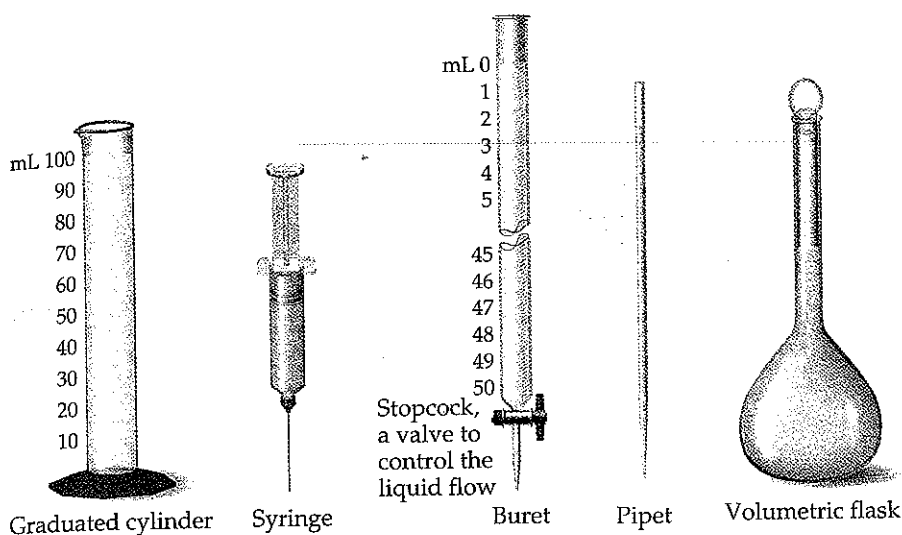

◀ **Figure 1.20 Common volumetric glassware.** The graduated cylinder, syringe, and buret are used in laboratories to deliver variable volumes of liquid. The pipet is used to deliver a specific volume of liquid. The volumetric flask contains a specific volume of liquid when filled to the mark.

GIVE IT SOME THOUGHT

Which of the following quantities represents a volume measurement: 15 m^2 ; $2.5 \times 10^2 \text{ m}^3$; 5.77 L/s ? How do you know?

Density

Density is a property of matter that is widely used to characterize a substance. Density is defined as the amount of mass in a unit volume of the substance:

$$\text{Density} = \frac{\text{mass}}{\text{volume}} \quad [1.3]$$

The densities of solids and liquids are commonly expressed in units of grams per cubic centimeter (g/cm^3) or grams per milliliter (g/mL). The densities of some common substances are listed in Table 1.6. It is no coincidence that the density of water is 1.00 g/mL ; the gram was originally defined as the mass of 1 mL of water at a specific temperature. Because most substances change volume when they are heated or cooled, densities are temperature dependent. When reporting densities, the temperature should be specified. If no temperature is reported, we usually assume that the temperature is 25°C , close to normal room temperature.

The terms *density* and *weight* are sometimes confused. A person who says that iron weighs more than air generally means that iron has a higher density than air— 1 kg of air has the same mass as 1 kg of iron, but the iron occupies a smaller volume, thereby giving it a higher density. If we combine two liquids that do not mix, the less dense liquid will float on the denser liquid.

TABLE 1.6 Densities of Some Selected Substances at 25°C

| Substance | Density (g/cm^3) |
|-----------------|-----------------------------|
| Air | 0.001 |
| Balsa wood | 0.16 |
| Ethanol | 0.79 |
| Water | 1.00 |
| Ethylene glycol | 1.09 |
| Table sugar | 1.59 |
| Table salt | 2.16 |
| Iron | 7.9 |
| Gold | 19.32 |

Chemistry Put to Work

CHEMISTRY IN THE NEWS

Chemistry is a very lively, active field of science. Because chemistry is so central to our lives, reports on matters of chemical significance appear in the news nearly every day. Some reports tell of recent breakthroughs in the development of new pharmaceuticals, materials, and processes. Others deal with environmental and public safety issues. As you study chemistry, we hope you will develop the skills to better understand the importance of chemistry in your life. By way of examples, here are summaries of a few recent stories in which chemistry plays a role.

Biofuels Reality Check

With the Energy Policy Act of 2005, the United States Congress has given a big push to fuels derived from biomass as a renewable, homegrown alternative to gasoline. The law requires that 4 billion gallons of the so-called renewable fuel be mixed with gasoline in 2007, increasing to 7.5 billion gallons by 2012. The United States currently consumes about 140 billion gallons of gasoline per year.

Although the Act does not dictate which renewable fuels to use, ethanol derived from corn currently dominates the alternatives with 40% of all gasoline now containing some ethanol. A blend of 10% ethanol and 90% gasoline, called E10, is the most common blend because it can be used in virtually all vehicles. Blends of 85% ethanol and 15% gasoline, called E85, are also available but can be used only with specially modified engines in what are called flexible-fuel vehicles (FFVs) (Figure 1.21 ▼).

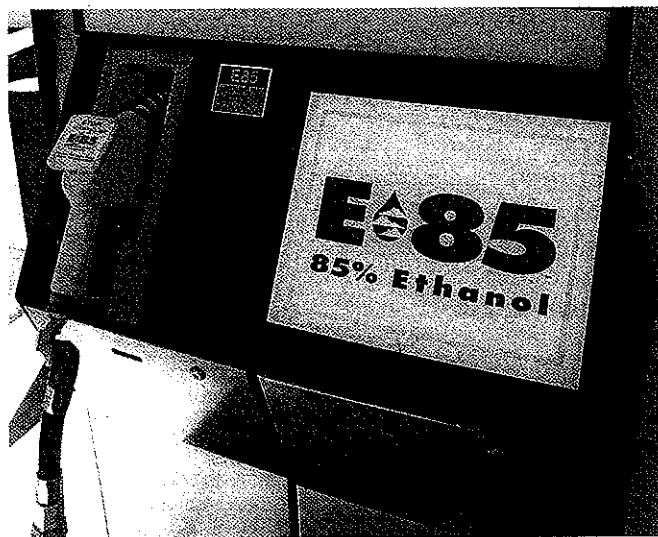

▲ Figure 1.21 A gasoline pump that dispenses E85 ethanol.

When it comes to ethanol's pros and cons, there is no shortage of disagreement. In 2006, researchers at the University of Minnesota calculated that "Even dedicating all U.S. corn and soybean production to biofuels would meet only 12% of gasoline demand and 6% of diesel demand." The conversion of a much wider range of plant material, making use of a much greater fraction of the available plant matter, into fuels will be necessary to improve these numbers substantially. Because most cellulose, which plants are formed does not readily convert to ethanol, a great deal of research will be needed to solve this challenge. Meanwhile, it is worth reflecting that a 3% improvement in vehicle efficiency of fuel use would displace more gasoline use than the entire 2006 US ethanol production.

New Element Created

A new entry has been made to the list of elements. The discovery of the newest and heaviest element—element 118—was announced in October 2006. The synthesis of element 118 resulted from studies performed from 2002 to 2006 at the Institute for Nuclear Research (JINR) in Dubna, Russia. Scientists and their collaborators from Lawrence Livermore National Laboratory in California announced that they produced three atoms of the new element, one atom in 2002 and two more in 2005.

The new element was formed by striking a target of californium atoms (element 98) with a highly energetic beam consisting of the nuclei of calcium atoms (element 20) in a device called a particle accelerator. Occasionally, the nuclei from the two different elements fused to form the new, superheavy element 118. The 2002 experiment took four months and used a beam of 2.5×10^{19} calcium atoms to produce a single atom of element 118.

The three atoms of element 118 created during these experiments came and went in a literal flash. On the average, only three atoms survived for just 0.9 milliseconds before decomposing.

These experimental results were met with praise but also caution from other scientists in the field, particularly given the difficult history of element 118. Another California laboratory, Lawrence Berkeley National Laboratory, announced that it discovered element 118 in 1999 but retracted the claim a few years later after an investigation found that one of the researchers had fabricated data.

This discovery brings the total number of elements discovered by the Livermore-Dubna collaboration to five: elements 113, 114, 115, 116, and 118. As of this writing, element 117 has not yet been named.

Important Antibiotic Modified to Combat Bacterial Resistance

Vancomycin is an antibiotic of last resort—used only when other antibacterial agents are ineffective. Some bacteria have developed a resistance to vancomycin, causing researchers to modify the molecular structure of the substance to make it more effective.

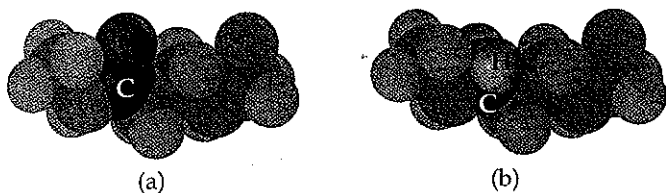

◀ **Figure 1.22 Comparing CO and CH₂ groups.** Two molecules, one containing the CO group (left) and one containing the CH₂ group (right), are shown. The subtle difference between these two molecules is like that produced when the structure of the much more complex vancomycin molecule was modified.

more effective in killing bacteria. This approach was based on the knowledge that vancomycin works by binding to a particular protein, called a glycoprotein, that is essential for forming the walls of bacterial cells. Researchers have now synthesized an analog of vancomycin in which a CO group in the molecule has been converted to a CH₂ group (Figure 1.22▲). This molecular modification increases the compound's binding affinity with the glycoprotein in the cell walls of vancomycin-resistant bacteria. The analog is 100 times more active than vancomycin against vancomycin-resistant bacteria.

The Hole Story

Ozone in the upper atmosphere protects life on Earth by blocking harmful ultraviolet rays coming from the sun. The "ozone hole" is a severe depletion of the ozone layer high above Antarctica. Human-produced compounds that release chlorine and bromine into the stratosphere are the primary cause of the ozone hole.

The production of ozone-depleting chemicals has been banned since 1996, although emissions of previously produced and stored amounts of those chemicals that are not destroyed or recycled will continue. Scientists had predicted that the ozone hole would disappear by 2050 because of the ban. The 2006 World Meteorological Organization/United Nations Environment Programme Scientific Assessment of Ozone De-

pletion, however, recently issued its report changing this estimate. Based on a combination of new ozone measurements, computer models, and revised estimates of the existing stores of ozone-depleting chemicals, scientists now estimate the date for full Antarctic ozone recovery to be 2065.

Replacing the Lightbulb through Chemistry

If you want to save the world from global warming, you can start by replacing incandescent lightbulbs, which waste about 90% of the energy supplied to them by producing heat. A promising place to look for replacement bulbs is in the field of light-emitting diodes (LEDs). Red LEDs and those emitting other colors are found everywhere these days: in flashlights, traffic lights, car taillights, and a host of electronics applications (Figure 1.23▼). But to really make it big in the world, LEDs need to be capable of producing white light at a reasonable cost.

Progress is being made in forming high-efficiency LEDs based on organic films that emit white light. In these devices a light-emitting material is sandwiched between two electrical connectors. When electricity passes through the organic film, oppositely charged particles combine and give off light. White organic LEDs have been steadily improving, and are now about as efficient as fluorescent tubes. More work needs to be done before these devices can replace the lightbulb, but progress has been rapid.

▶ **Figure 1.23 Sign made from LEDs.**

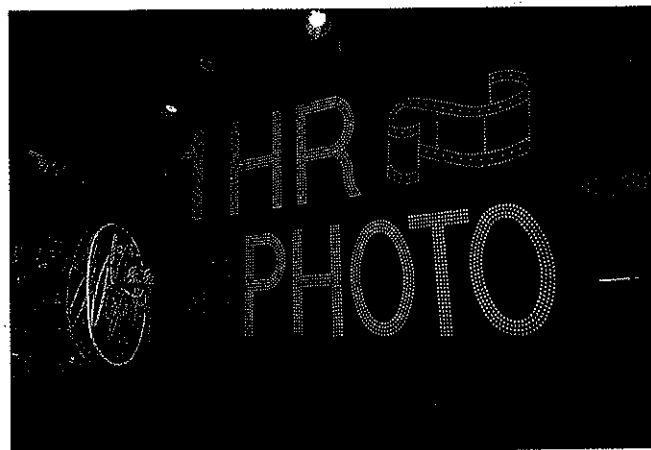

short-
ity of
and
gas-
vider
ction
o im-
se of
ol, a
ging
ove-
aso-

pro-
18—
: 118
oint
[NR
ore
had
:002

ali-
on-
rice
the
su-
ths
the

ex-
the
ng.
lso
he
he
it
vo
re-
at-
its
as

n
re
o
it

SAMPLE EXERCISE 1.4 | Determining Density and Using Density to Determine Volume or Mass

- (a) Calculate the density of mercury if 1.00×10^2 g occupies a volume of 7.36 cm^3 .
 (b) Calculate the volume of 65.0 g of the liquid methanol (wood alcohol) if its density is 0.791 g/mL.
 (c) What is the mass in grams of a cube of gold (density = 19.32 g/cm^3) if the length of the cube is 2.00 cm?

SOLUTION

(a) We are given mass and volume, so Equation 1.3 yields

$$\text{Density} = \frac{\text{mass}}{\text{volume}} = \frac{1.00 \times 10^2 \text{ g}}{7.36 \text{ cm}^3} = 13.6 \text{ g/cm}^3$$

(b) Solving Equation 1.3 for volume and then using the given mass and density gives

$$\text{Volume} = \frac{\text{mass}}{\text{density}} = \frac{65.0 \text{ g}}{0.791 \text{ g/mL}} = 82.2 \text{ mL}$$

(c) We can calculate the mass from the volume of the cube and its density. The volume of a cube is given by its length cubed:

$$\text{Volume} = (2.00 \text{ cm})^3 = (2.00)^3 \text{ cm}^3 = 8.00 \text{ cm}^3$$

Solving Equation 1.3 for mass and substituting the volume and density of the cube, we have

$$\text{Mass} = \text{volume} \times \text{density} = (8.00 \text{ cm}^3)(19.32 \text{ g/cm}^3) = 155 \text{ g}$$

PRACTICE EXERCISE

- (a) Calculate the density of a 374.5-g sample of copper if it has a volume of 41.8 cm^3 . (b) A student needs 15.0 g of ethanol for an experiment. If the density of ethanol is 0.789 g/mL, how many milliliters of ethanol are needed? (c) What is the mass, in grams, of 25.0 mL of mercury (density = 13.6 g/mL)?
 Answers: (a) 8.96 g/cm^3 , (b) 19.0 mL, (c) 340 g

1.5 UNCERTAINTY IN MEASUREMENT

Two kinds of numbers are encountered in scientific work: *exact numbers* (those whose values are known exactly) and *inexact numbers* (those whose values have some uncertainty). Most of the exact numbers that we will encounter in this course have defined values. For example, there are exactly 12 eggs in a dozen, exactly 1000 g in a kilogram, and exactly 2.54 cm in an inch. The number 1 is also an exact number. Exact numbers can also result from counting numbers of objects. For example, we can count the exact number of marbles in a jar or the exact number of people in a classroom.

Numbers obtained by measurement are always *inexact*. The equipment used to measure quantities always has inherent limitations (equipment error) and there are differences in how different people make the same measurement (human errors). Suppose that ten students with ten balances are given the same dime and told to determine its mass. The ten measurements will probably vary slightly from one another for various reasons. The balances might be calibrated slightly differently, and there might be differences in how each student reads the mass from the balance. Remember: *Uncertainties always exist in measured quantities*. Counting very large numbers of objects usually has some associated error as well. Consider, for example, how difficult it is to obtain accurate census information for a city or vote counts for an election.

GIVE IT SOME THOUGHT

Which of the following is an inexact quantity: (a) the number of people in your chemistry class, (b) the mass of a penny, (c) the number of grams in a kilogram?

Precision and Accuracy

The terms precision and accuracy are often used in discussing the uncertainty of measured values. **Precision** is a measure of how closely individual measurements

agree with one another. **Accuracy** refers to how closely individual measurements agree with the correct, or "true," value. The analogy of darts stuck in a dartboard pictured in Figure 1.24 illustrates the difference between these two concepts.

In the laboratory we often perform several different "trials" of the same experiment and average the results. The precision of the measurements is often expressed in terms of what is called the *standard deviation*, which reflects how much the individual measurements differ from the average, as described in Appendix A. We gain confidence in our measurements if we obtain nearly the same value each time—that is, the standard deviation is small. Figure 1.24 should remind us, however, that precise measurements could be inaccurate. For example, if a very sensitive balance is poorly calibrated, the masses we measure will be consistently either high or low. They will be inaccurate even if they are precise.

Significant Figures

Suppose you determine the mass of a dime on a balance capable of measuring to the nearest 0.0001 g. You could report the mass as 2.2405 ± 0.0001 g. The \pm notation (read "plus or minus") expresses the magnitude of the uncertainty of your measurement. In much scientific work we drop the \pm notation with the understanding that there is always some uncertainty in the last digit of the measured quantity. That is, *measured quantities are generally reported in such a way that only the last digit is uncertain*.

Figure 1.25 shows a thermometer with its liquid column between the scale marks. We can read the certain digits from the scale and estimate the uncertain one. From the scale marks on the thermometer, we see that the liquid is between the 25 °C and 30 °C marks. We might estimate the temperature to be 27 °C, being somewhat uncertain of the second digit of our measurement.

All digits of a measured quantity, including the uncertain one, are called **significant figures**. A measured mass reported as 2.2 g has two significant figures, whereas one reported as 2.2405 g has five significant figures. The greater the number of significant figures, the greater is the certainty implied for the measurement. When multiple measurements are made of a quantity, the results can be averaged, and the number of significant figures estimated by using statistical methods.

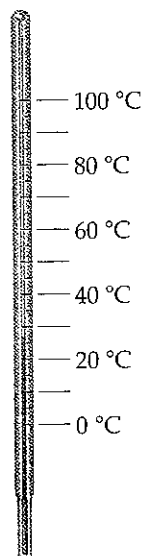

◀ **Figure 1.25 Significant figures in measurements.** The thermometer has markings every 5 °C. The temperature is between 25 °C and 30 °C and is approximately 27 °C. The two significant figures in the measurement include the second digit, which is estimated by reading between the scale marks.

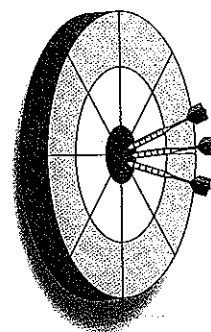

Good accuracy
Good precision

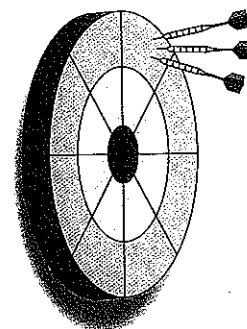

Poor accuracy
Good precision

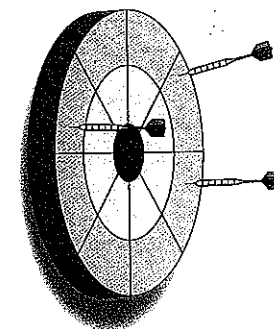

Poor accuracy
Poor precision

▲ **Figure 1.24 Precision and accuracy.** The distribution of darts on a target illustrates the difference between accuracy and precision.

SAMPLE EXERCISE 1.5 | Relating Significant Figures to the Uncertainty of a Measurement

What difference exists between the measured values 4.0 g and 4.00 g?

SOLUTION

Many people would say there is no difference, but a scientist would note the difference in the number of significant figures in the two measurements. The value 4.0 has two significant figures, while 4.00 has three. This difference implies that the first measurement has more uncertainty. A mass of 4.0 g indicates that the uncertainty is in the first decimal place of the measurement. Thus, the mass might be anything between 3.9 and 4.1 g, which we can represent as 4.0 ± 0.1 g. A measurement of 4.00 g implies that the uncertainty is in the second decimal place. Thus, the mass might be anything between 3.99 and 4.01 g, which we can represent as 4.00 ± 0.01 g. Without further information, we cannot be sure whether the difference in uncertainties of the two measurements reflects the precision or accuracy of the measurement.

PRACTICE EXERCISE

A balance has a precision of ± 0.001 g. A sample that has a mass of about 25 g is placed on this balance. How many significant figures should be reported for this measurement?

Answer: five, as in the measurement 24.995 g, the uncertainty being in the third decimal place



To determine the number of significant figures in a reported measurement, read the number from left to right, counting the digits starting with the first digit that is not zero. *In any measurement that is properly reported, all nonzero digits are significant.* Zeros, however, can be used either as part of the measured value or merely to locate the decimal point. Thus, zeros may or may not be significant, depending on how they appear in the number. The following guidelines describe the different situations involving zeros:

1. Zeros *between* nonzero digits are always significant—1005 kg (four significant figures); 1.03 cm (three significant figures).
2. Zeros *at the beginning* of a number are never significant; they merely indicate the position of the decimal point—0.02 g (one significant figure); 0.0026 cm (two significant figures).
3. Zeros *at the end* of a number are significant if the number contains a decimal point—0.0200 g (three significant figures); 3.0 cm (two significant figures).

A problem arises when a number ends with zeros but contains no decimal point. In such cases, it is normally assumed that the zeros are not significant. Exponential notation (Appendix A) can be used to clearly indicate whether zeros at the end of a number are significant. For example, a mass of 10,300 g can be written in exponential notation showing three, four, or five significant figures depending on how the measurement is obtained:

$$\begin{aligned} 1.03 \times 10^4 \text{ g} & \quad (\text{three significant figures}) \\ 1.030 \times 10^4 \text{ g} & \quad (\text{four significant figures}) \\ 1.0300 \times 10^4 \text{ g} & \quad (\text{five significant figures}) \end{aligned}$$

In these numbers all the zeros to the right of the decimal point are significant (rules 1 and 3). (The exponential term does not add to the number of significant figures.)

SAMPLE EXERCISE 1.6 | Determining the Number of Significant Figures in a Measurement

How many significant figures are in each of the following numbers (assume that each number is a measured quantity): (a) 4.003, (b) 6.023×10^{23} , (c) 5000?

SOLUTION

(a) Four; the zeros are significant figures. (b) Four; the exponential term does not add to the number of significant figures. (c) One. We assume that the zeros are not significant when there is no decimal point shown. If the number has more significant figures, a decimal point should be employed or the number written in exponential notation. Thus, 5000. has four significant figures, whereas 5.00×10^3 has three.

PRACTICE EXERCISE

How many significant figures are in each of the following measurements: (a) 3.549 g, (b) 2.3×10^4 cm, (c) 0.00134 m^3 ?

Answers: (a) four, (b) two, (c) three

Significant Figures in Calculations

When carrying measured quantities through calculations, *the least certain measurement limits the certainty of the calculated quantity and thereby determines the number of significant figures in the final answer.* The final answer should be reported with only one uncertain digit. To keep track of significant figures in calculations, we will make frequent use of two rules, one for addition and subtraction, and another for multiplication and division.

1. For addition and subtraction, the result has the same number of decimal places as the measurement with the fewest decimal places. When the result contains more than the correct number of significant figures, it must be rounded off. Consider the following example in which the uncertain digits appear in color:

| | | |
|---------------------------|---------|--|
| This number limits | 20.42 | ← two decimal places |
| the number of significant | 1.322 | ← three decimal places |
| figures in the result → | 83.1 | ← one decimal place |
| | 104.842 | ← round off to one decimal place (104.8) |

We report the result as 104.8 because 83.1 has only one decimal place.

2. For multiplication and division, the result contains the same number of significant figures as the measurement with the fewest significant figures. When the result contains more than the correct number of significant figures, it must be rounded off. For example, the area of a rectangle whose measured edge lengths are 6.221 cm and 5.2 cm should be reported as 32 cm^2 even though a calculator shows the product of 6.221 and 5.2 to have more digits:

$$\text{Area} = (6.221 \text{ cm})(5.2 \text{ cm}) = 32.3492 \text{ cm}^2 \Rightarrow \text{round off to } 32 \text{ cm}^2$$

We round off to two significant figures because the least precise number—5.2 cm—has only two significant figures.

Notice that for addition and subtraction, decimal places are counted; whereas for multiplication and division, significant figures are counted.

In determining the final answer for a calculated quantity, *exact numbers* can be treated as if they have an infinite number of significant figures. This rule applies to many definitions between units. Thus, when we say, "There are 12 inches in 1 foot," the number 12 is exact, and we need not worry about the number of significant figures in it.

In *rounding off numbers*, look at the leftmost digit to be removed:

- If the leftmost digit removed is less than 5, the preceding number is left unchanged. Thus, rounding 7.248 to two significant figures gives 7.2.
- If the leftmost digit removed is 5 or greater, the preceding number is increased by 1. Rounding 4.735 to three significant figures gives 4.74, and rounding 2.376 to two significant figures gives 2.4.*

SAMPLE EXERCISE 1.7 | Determining the Number of Significant Figures in a Calculated Quantity

The width, length, and height of a small box are 15.5 cm, 27.3 cm, and 5.4 cm, respectively. Calculate the volume of the box, using the correct number of significant figures in your answer.

*Your instructor may want you to use a slight variation on the rule when the leftmost digit to be removed is exactly 5, with no following digits or only zeros. One common practice is to round up to the next higher number if that number will be even, and down to the next lower number otherwise. Thus, 4.7350 would be rounded to 4.74, and 4.7450 would also be rounded to 4.74.

SOLUTION

The product of the width, length, and height determines the volume of a box. In reporting the product, we can show only as many significant figures as given in the dimension with the fewest significant figures, that for the height (two significant figures):

$$\begin{aligned}\text{Volume} &= \text{width} \times \text{length} \times \text{height} \\ &= (15.5 \text{ cm})(27.3 \text{ cm})(5.4 \text{ cm}) = 2285.01 \text{ cm}^3 \Rightarrow 2.3 \times 10^3 \text{ cm}^3\end{aligned}$$

When we use a calculator to do this calculation, the display shows 2285.01, which must round off to two significant figures. Because the resulting number is 2300, it is best reported in exponential notation, 2.3×10^3 , to clearly indicate two significant figures.

PRACTICE EXERCISE

It takes 10.5 s for a sprinter to run 100.00 m. Calculate the average speed of the sprinter in meters per second, and express the result to the correct number of significant figures.

Answer: 9.52 m/s (three significant figures)

SAMPLE EXERCISE 1.8 | Determining the Number of Significant Figures in a Calculated Quantity

A gas at 25 °C fills a container whose volume is $1.05 \times 10^3 \text{ cm}^3$. The container plus gas have a mass of 837.6 g. The container when emptied of all gas, has a mass of 836.2 g. What is the density of the gas at 25 °C?

SOLUTION

To calculate the density, we must know both the mass and the volume of the gas. The mass of the gas is just the difference in the masses of the full and empty container:

$$(837.6 - 836.2) \text{ g} = 1.4 \text{ g}$$

In subtracting numbers, we determine the number of significant figures in our result by counting decimal places in each quantity. In this case each quantity has one decimal place. Thus, the mass of the gas, 1.4 g, has one decimal place.

Using the volume given in the question, $1.05 \times 10^3 \text{ cm}^3$, and the definition of density, we have

$$\begin{aligned}\text{Density} &= \frac{\text{mass}}{\text{volume}} = \frac{1.4 \text{ g}}{1.05 \times 10^3 \text{ cm}^3} \\ &= 1.3 \times 10^{-3} \text{ g/cm}^3 = 0.0013 \text{ g/cm}^3\end{aligned}$$

In dividing numbers, we determine the number of significant figures in our result by counting the number of significant figures in each quantity. There are two significant figures in our answer, corresponding to the smaller number of significant figures in the numbers that form the ratio. Notice that in this example, following the rules for determining significant figures gives an answer containing only two significant figures, even though each of the measured quantities contained at least three significant figures.

PRACTICE EXERCISE

To how many significant figures should the mass of the container be measured (with and without the gas) in Sample Exercise 1.8 for the density to be calculated to three significant figures?

Answer: five (For the difference in the two masses to have three significant figures, there must be two decimal places in the masses of the filled and empty containers. Therefore, each mass must be measured to five significant figures.)

When a calculation involves two or more steps and you write down answers for intermediate steps, retain at least one additional digit—past the number of significant figures—for the intermediate answers. This procedure ensures that small errors from rounding at each step do not combine to affect the final result. When using a calculator, you may enter the numbers one after another, rounding only the final answer. Accumulated rounding-off errors may account for small differences among results you obtain and answers given in the text for numerical problems.

1.6 DIMENSIONAL ANALYSIS

Throughout the text we use an approach called **dimensional analysis** as a method in problem solving. In dimensional analysis we carry units through all calculations. Units are multiplied together, divided into each other, or “cancel

Using dimensional analysis helps ensure that the solutions to problems yield the proper units. Moreover, it provides a systematic way of solving many numerical problems and of checking our solutions for possible errors.

The key to using dimensional analysis is the correct use of conversion factors to change one unit into another. A **conversion factor** is a fraction whose numerator and denominator are the same quantity expressed in different units. For example, 2.54 cm and 1 in. are the same length, $2.54 \text{ cm} = 1 \text{ in.}$ This relationship allows us to write two conversion factors:

$$\frac{2.54 \text{ cm}}{1 \text{ in.}} \quad \text{and} \quad \frac{1 \text{ in.}}{2.54 \text{ cm}}$$

We use the first of these factors to convert inches to centimeters. For example, the length in centimeters of an object that is 8.50 in. long is given by

$$\text{Number of centimeters} = (8.50 \text{ in.}) \frac{2.54 \text{ cm}}{1 \text{ in.}} = 21.6 \text{ cm}$$

Desired unit

Given unit

The unit inches in the denominator of the conversion factor cancels the unit inches in the given data (8.50 inches). The unit centimeters in the numerator of the conversion factor becomes the unit of the final answer. Because the numerator and denominator of a conversion factor are equal, multiplying any quantity by a conversion factor is equivalent to multiplying by the number 1 and so does not change the intrinsic value of the quantity. The length 8.50 in. is the same as the length 21.6 cm.

In general, we begin any conversion by examining the units of the given data and the units we desire. We then ask ourselves what conversion factors we have available to take us from the units of the given quantity to those of the desired one. When we multiply a quantity by a conversion factor, the units multiply and divide as follows:

$$\text{Given unit} \times \frac{\text{desired unit}}{\text{given unit}} = \text{desired unit}$$

If the desired units are not obtained in a calculation, then an error must have been made somewhere. Careful inspection of units often reveals the source of the error.

■ SAMPLE EXERCISE 1.9 | Converting Units

If a woman has a mass of 115 lb, what is her mass in grams? (Use the relationships between units given on the back inside cover of the text.)

SOLUTION

Because we want to change from lb to g, we look for a relationship between these units of mass. From the back inside cover we have $1 \text{ lb} = 453.6 \text{ g}$. To cancel pounds and leave grams, we write the conversion factor with grams in the numerator and pounds in the denominator:

$$\text{Mass in grams} = (115 \text{ lb}) \left(\frac{453.6 \text{ g}}{1 \text{ lb}} \right) = 5.22 \times 10^4 \text{ g}$$

The answer can be given to only three significant figures, the number of significant figures in 115 lb. The process we have used is diagrammed in the margin.

■ PRACTICE EXERCISE

By using a conversion factor from the back inside cover, determine the length in kilometers of a 500.0-mi automobile race.

Answer: 804.7 km

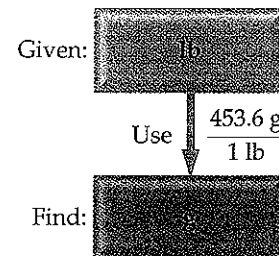

Strategies in Chemistry

ESTIMATING ANSWERS

A friend once remarked cynically that calculators let you get the wrong answer more quickly. What he was implying by that remark was that unless you have the correct strategy for solving a problem and have punched in the correct numbers, the answer will be incorrect. If you learn to *estimate* answers, however, you will be able to check whether the answers to your calculations are reasonable.

The idea is to make a rough calculation using numbers that are rounded off in such a way that the arithmetic can easily be performed without a calculator. This approach is often referred to as making a "ballpark" estimate, meaning that while it does not give an exact answer, it gives one that is roughly the right size. By working with units using dimensional analysis and by estimating answers, we can readily check the reasonableness of our answers to calculations.

GIVE IT SOME THOUGHT

How do we determine how many digits to use in conversion factors, such as the relationship between pounds and grams in Sample Exercise 1.9?

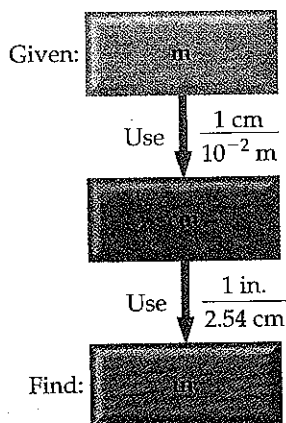

Using Two or More Conversion Factors

It is often necessary to use several conversion factors in solving a problem. For example, let's convert the length of an 8.00-m rod to inches. The table on the back inside cover does not give the relationship between meters and inches. It *does*, however, give the relationship between centimeters and inches (1 in. = 2.54 cm). From our knowledge of metric prefixes, we know 1 cm = 10^{-2} m. Thus, we can convert step by step, first from meters to centimeters, and then from centimeters to inches as diagrammed in the margin.

Combining the given quantity (8.00 m) and the two conversion factors we have

$$\text{Number of inches} = (8.00 \text{ m}) \left(\frac{1 \text{ cm}}{10^{-2} \text{ m}} \right) \left(\frac{1 \text{ in.}}{2.54 \text{ cm}} \right) = 315 \text{ in.}$$

The first conversion factor is applied to cancel meters and convert the length to centimeters. Thus, meters are written in the denominator and centimeters in the numerator. The second conversion factor is written to cancel centimeters; it has centimeters in the denominator and inches, the desired unit, in the numerator.

SAMPLE EXERCISE 1.10 | Converting Units Using Two or More Conversion Factors

The average speed of a nitrogen molecule in air at 25 °C is 515 m/s. Convert this speed to miles per hour.

SOLUTION

To go from the given units, m/s, to the desired units, mi/hr, we must convert m to miles and seconds to hours. From our knowledge of metric prefixes we know 1 km = 10^3 m. From the relationships given on the back inside cover of the book we find that 1 mi = 1.6093 km. Thus, we can convert m to km and then convert km to mi. From our knowledge of time we know that 60 s = 1 min and 60 min = 1 hr. Thus, we can convert s to min and then convert min to hr. The overall process is diagrammed in the margin.

Applying first the conversions for distance and then those for time, we can set up one long equation in which unwanted units are canceled:

$$\begin{aligned} \text{Speed in mi/hr} &= \left(515 \frac{\text{m}}{\text{s}} \right) \left(\frac{1 \text{ km}}{10^3 \text{ m}} \right) \left(\frac{1 \text{ mi}}{1.6093 \text{ km}} \right) \left(\frac{60 \text{ s}}{1 \text{ min}} \right) \left(\frac{60 \text{ min}}{1 \text{ hr}} \right) \\ &= 1.15 \times 10^3 \text{ mi/hr} \end{aligned}$$

Our answer has the desired units. We can check our calculation, using the estimation procedure described in the previous "Strategies" box. The given speed is

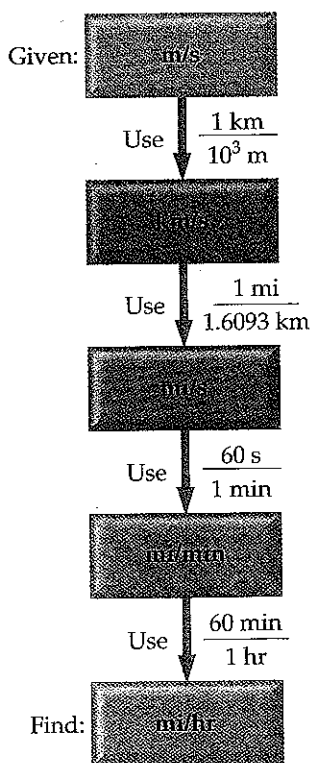

500 m/s. Dividing by 1000 converts m to km, giving 0.5 km/s. Because 1 mi is about 1.6 km, this speed corresponds to $0.5/1.6 = 0.3$ mi/s. Multiplying by 60 gives about $0.3 \times 60 = 20$ mi/min. Multiplying again by 60 gives $20 \times 60 = 1200$ mi/hr. The approximate solution (about 1200 mi/hr) and the detailed solution (1150 mi/hr) are reasonably close. The answer to the detailed solution has three significant figures, corresponding to the number of significant figures in the given speed in m/s.

■ PRACTICE EXERCISE

A car travels 28 mi per gallon of gasoline. How many kilometers per liter will it go?
Answer: 12 km/L

Conversions Involving Volume

The conversion factors previously noted convert from one unit of a given measure to another unit of the same measure, such as from length to length. We also have conversion factors that convert from one measure to a different one. The density of a substance, for example, can be treated as a conversion factor between mass and volume. Suppose that we want to know the mass in grams of two cubic inches (2.00 in.^3) of gold, which has a density of 19.3 g/cm^3 . The density gives us the following factors:

$$\frac{19.3 \text{ g}}{1 \text{ cm}^3} \quad \text{and} \quad \frac{1 \text{ cm}^3}{19.3 \text{ g}}$$

Because the answer we want is a mass in grams, we can see that we will use the first of these factors, which has mass in grams in the numerator. To use this factor, however, we must first convert cubic inches to cubic centimeters. The relationship between in.^3 and cm^3 is not given on the back inside cover, but the relationship between inches and centimeters is given: $1 \text{ in.} = 2.54 \text{ cm}$ (exactly). Cubing both sides of this equation gives $(1 \text{ in.})^3 = (2.54 \text{ cm})^3$, from which we write the desired conversion factor:

$$\frac{(2.54 \text{ cm})^3}{(1 \text{ in.})^3} = \frac{(2.54)^3 \text{ cm}^3}{(1)^3 \text{ in.}^3} = \frac{16.39 \text{ cm}^3}{1 \text{ in.}^3}$$

Notice that both the numbers and the units are cubed. Also, because 2.54 is an exact number, we can retain as many digits of $(2.54)^3$ as we need. We have used four, one more than the number of digits in the density (19.3 g/cm^3). Applying our conversion factors, we can now solve the problem:

$$\text{Mass in grams} = (2.00 \text{ in.}^3) \left(\frac{16.39 \text{ cm}^3}{1 \text{ in.}^3} \right) \left(\frac{19.3 \text{ g}}{1 \text{ cm}^3} \right) = 633 \text{ g}$$

The procedure is diagrammed below. The final answer is reported to three significant figures, the same number of significant figures as in 2.00 in.^3 and 19.3 g .

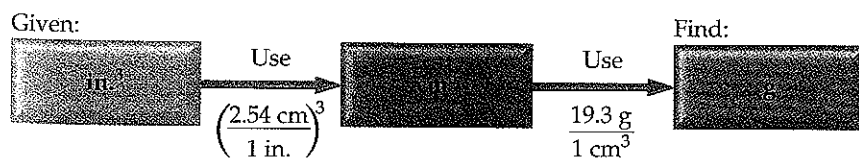

■ SAMPLE EXERCISE 1.11 | Converting Volume Units

Earth's oceans contain approximately $1.36 \times 10^9 \text{ km}^3$ of water. Calculate the volume in liters.

SOLUTION

This problem involves conversion of km^3 to L. From the back inside cover of the text we find $1 \text{ L} = 10^{-3} \text{ m}^3$, but there is no relationship listed involving km^3 . From our

knowledge of metric prefixes, however, we have $1 \text{ km} = 10^3 \text{ m}$ and we can use this relationship between lengths to write the desired conversion factor between volume

$$\left(\frac{10^3 \text{ m}}{1 \text{ km}}\right)^3 = \frac{10^9 \text{ m}^3}{1 \text{ km}^3}$$

Thus, converting from km^3 to m^3 to L, we have

$$\text{Volume in liters} = (1.36 \times 10^9 \text{ km}^3) \left(\frac{10^9 \text{ m}^3}{1 \text{ km}^3}\right) \left(\frac{1 \text{ L}}{10^{-3} \text{ m}^3}\right) = 1.36 \times 10^{21} \text{ L}$$

■ PRACTICE EXERCISE

If the volume of an object is reported as 5.0 ft^3 , what is the volume in cubic meters?
Answer: 0.14 m^3

Strategies in Chemistry THE IMPORTANCE OF PRACTICE

If you have ever played a musical instrument or participated in athletics, you know that the keys to success are practice and discipline. You cannot learn to play a piano merely by listening to music, and you cannot learn how to play basketball merely by watching games on television. Likewise, you cannot learn chemistry by merely watching your instructor do it. Simply reading this book, listening to lectures, or reviewing notes will not usually be sufficient when exam time comes around. Your task is not merely to understand how someone else uses chemistry, but to be able to do it yourself. That takes practice on a regular basis, and anything that you have to do on a regular basis requires self-discipline until it becomes a habit.

Throughout the book, we have provided sample exercises in which the solutions are shown in detail. A practice exercise, for which only the answer is given, accompanies each sample exercise. It is important that you use these exercises as learn-

ing aids. End-of-chapter exercises provide additional questions to help you understand the material in the chapter. Red numbers indicate exercises for which answers are given at the back of the book. A review of basic mathematics is given in Appendix A.

The practice exercises in this text and the homework assignments given by your instructor provide the minimal practice that you will need to succeed in your chemistry course. Only by working all the assigned problems will you face the full range of difficulty and coverage that your instructor expects you to master for exams. There is no substitute for a determined and perhaps lengthy effort to work problems on your own. If you are stuck on a problem, however, ask for help from your instructor, a teaching assistant, a tutor, or a fellow student. Spending an inordinate amount of time on a single exercise is rarely effective unless you know that it is particularly challenging and requires extensive thought and effort.

■ SAMPLE EXERCISE 1.12 | Conversions Involving Density

What is the mass in grams of 1.00 gal of water? The density of water is 1.00 g/mL .

SOLUTION

Before we begin solving this exercise, we note the following:

1. We are given 1.00 gal of water (the known, or given, quantity) and asked to calculate its mass in grams (the unknown).
2. We have the following conversion factors either given, commonly known, available on the back inside cover of the text:

$$\frac{1.00 \text{ g water}}{1 \text{ mL water}} \quad \frac{1 \text{ L}}{1000 \text{ mL}} \quad \frac{1 \text{ L}}{1.057 \text{ qt}} \quad \frac{1 \text{ gal}}{4 \text{ qt}}$$

The first of these conversion factors must be used as written (with grams in the numerator) to give the desired result, whereas the last conversion factor must be inverted in order to cancel gallons:

$$\begin{aligned} \text{Mass in grams} &= (1.00 \text{ gal}) \left(\frac{4 \text{ qt}}{1 \text{ gal}}\right) \left(\frac{1 \text{ L}}{1.057 \text{ qt}}\right) \left(\frac{1000 \text{ mL}}{1 \text{ L}}\right) \left(\frac{1.00 \text{ g}}{1 \text{ mL}}\right) \\ &= 3.78 \times 10^3 \text{ g water} \end{aligned}$$

The units of our final answer are appropriate, and we've also taken care of our significant figures. We can further check our calculation by the estimation procedure. We can round 1.057 off to 1. Focusing on the numbers that do not equal 1 then gives merely $4 \times 1000 = 4000 \text{ g}$, in agreement with the detailed calculation.

In cases such as this you may also be able to use common sense to assess the reasonableness of your answer. In this case we know that most people can lift

gallon of milk with one hand, although it would be tiring to carry it around all day. Milk is mostly water and will have a density that is not too different than water. Therefore, we might estimate that in familiar units a gallon of water would have mass that was more than 5 lbs but less than 50 lbs. The mass we have calculated is $3.78 \text{ kg} \times 2.2 \text{ lb/kg} = 8.3 \text{ lbs}$ —an answer that is reasonable at least as an order of magnitude estimate.

■ PRACTICE EXERCISE

The density of benzene is 0.879 g/mL . Calculate the mass in grams of 1.00 qt of benzene.

Answer: 832 g

CHAPTER REVIEW

Following each chapter you will find a summary that highlights important content of the chapter. The summary contains all the key terms from the chapter in their contexts. A list of key skills and key equations follows the summary. These review materials are important tools to help you prepare for exams.

SUMMARY AND KEY TERMS

Introduction and Section 1.1 Chemistry is the study of the composition, structure, properties, and changes of **matter**. The composition of matter relates to the kinds of **elements** it contains. The structure of matter relates to the ways the **atoms** of these elements are arranged. A **property** is any characteristic that gives a sample of matter its unique identity. A **molecule** is an entity composed of two or more atoms with the atoms attached to one another in a specific way.

Section 1.2 Matter exists in three physical states, **gas**, **liquid**, and **solid**, which are known as the **states of matter**. There are two kinds of **pure substances**: **elements** and **compounds**. Each element has a single kind of atom and is represented by a chemical symbol consisting of one or two letters, with the first letter capitalized. Compounds are composed of two or more elements joined chemically. The **law of constant composition**, also called the **law of definite proportions**, states that the elemental composition of a pure compound is always the same. Most matter consists of a mixture of substances. **Mixtures** have variable compositions and can be either homogeneous or heterogeneous; homogeneous mixtures are called **solutions**.

Section 1.3 Each substance has a unique set of **physical properties** and **chemical properties** that can be used to identify it. During a **physical change**, matter does not change its composition. **Changes of state** are physical changes. In a **chemical change (chemical reaction)** a substance is transformed into a chemically different substance. **Intensive properties** are independent of the amount of matter examined and are used to identify substances. **Extensive properties** relate to the amount of substance present. Differences in physical and chemical properties are used to separate substances.

The **scientific method** is a dynamic process used to answer questions about our physical world. Observations

and experiments lead to **scientific laws**, general rules that summarize how nature behaves. Observations also lead to tentative explanations or **hypotheses**. As a hypothesis is tested and refined, a **theory** may be developed.

Section 1.4 Measurements in chemistry are made using the **metric system**. Special emphasis is placed on a particular set of metric units called **SI units**, which are based on the meter, the kilogram, and the second as the basic units of length, mass, and time, respectively. The metric system employs a set of prefixes to indicate decimal fractions or multiples of the base units. The SI temperature scale is the **Kelvin scale**, although the **Celsius scale** is frequently used as well. **Density** is an important property that equals mass divided by volume.

Section 1.5 All measured quantities are inexact to some extent. The **precision** of a measurement indicates how closely different measurements of a quantity agree with one another. The **accuracy** of a measurement indicates how well a measurement agrees with the accepted or "true" value. The **significant figures** in a measured quantity include one estimated digit, the last digit of the measurement. The significant figures indicate the extent of the uncertainty of the measurement. Certain rules must be followed so that a calculation involving measured quantities is reported with the appropriate number of significant figures.

Section 1.6 In the **dimensional analysis** approach to problem solving, we keep track of units as we carry measurements through calculations. The units are multiplied together, divided into each other, or canceled like algebraic quantities. Obtaining the proper units for the final result is an important means of checking the method of calculation. When converting units and when carrying out several other types of problems, **conversion factors** can be used. These factors are ratios constructed from valid relations between equivalent quantities.

KEY SKILLS

- Distinguish among elements, compounds, and mixtures.
- Memorize symbols of common elements and common metric prefixes.
- Use significant figures, scientific notation, metric units, and dimensional analysis in calculations.

KEY EQUATIONS

$$\bullet K = ^\circ\text{C} + 273.15 \quad [1.1]$$

$$\bullet ^\circ\text{C} = \frac{5}{9} (^{\circ}\text{F} - 32) \quad \text{or} \quad ^{\circ}\text{F} = \frac{9}{5} (^{\circ}\text{C}) + 32 \quad [1.2]$$

$$\bullet \text{Density} = \frac{\text{mass}}{\text{volume}} \quad [1.3]$$

Interconverting between Celsius ($^{\circ}\text{C}$) and Kelvin (K) temperatures scales

Interconverting between Celsius ($^{\circ}\text{C}$) and Fahrenheit ($^{\circ}\text{F}$) temperature scales

Definition of density

VISUALIZING CONCEPTS

The exercises in this section are intended to probe your understanding of key concepts rather than your ability to utilize formulas and perform calculations. Those exercises with red exercise numbers have answers in the back of the book.

- 1.1 Which of the following figures represents (a) a pure element, (b) a mixture of two elements, (c) a pure compound, (d) a mixture of an element and a compound? (More than one picture might fit each description.) [Section 1.2]

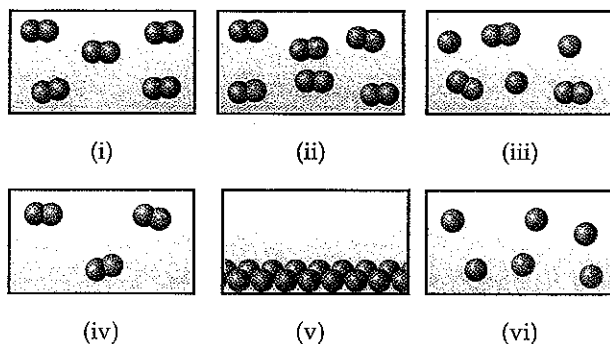

- 1.2 Does the following diagram represent a chemical or physical change? How do you know? [Section 1.3]

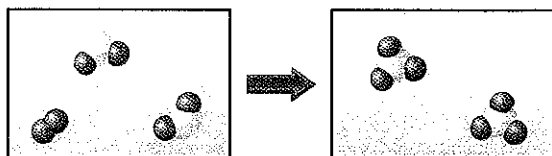

- 1.3 Identify each of the following as measurements of length, area, volume, mass, density, time, or temperature: (a) 5 ns, (b) 5.5 kg/m^3 , (c) 0.88 pm, (d) 540 km^2 , (e) 173 K, (f) 2 mm^3 , (g) $23 ^\circ\text{C}$. [Section 1.4]

- 1.4 Three spheres of equal size are composed of aluminum (density = 2.70 g/cm^3), silver (density = 10.49 g/cm^3), and nickel (density = 8.90 g/cm^3). List the spheres from lightest to heaviest.

- 1.5 The following dartboards illustrate the types of errors often seen when one measurement is repeated several

times. The bull's-eye represents the "true value," and the darts represent the experimental measurements. Which board best represents each of the following scenarios: (a) measurements both accurate and precise, (b) measurements precise but inaccurate, (c) measurements imprecise but yield an accurate average? [Section 1.5]

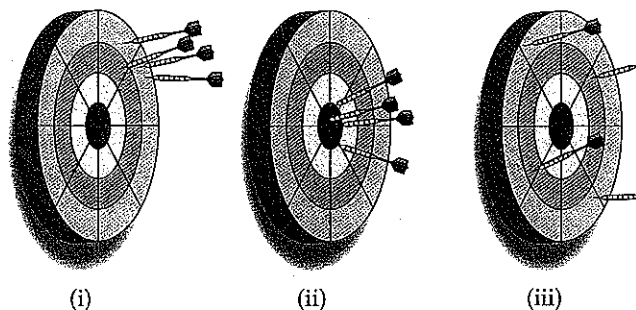

- 1.6 (a) What is the length of the pencil in the following figure if the scale reads in centimeters? How many significant figures are there in this measurement? (b) An oven thermometer with a circular scale reading degrees Fahrenheit is shown. What temperature does the scale indicate? How many significant figures are in the measurement? [Section 1.5]

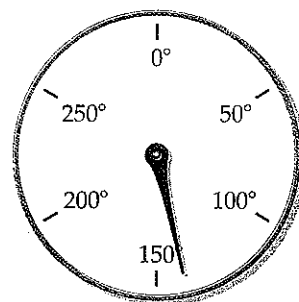

- 1.7 What is wrong with the following statement? Twenty years ago an ancient artifact was determined to be 1900 years old. It must now be 1920 years old. [Section 1.5]
- 1.8 (a) How many significant figures should be reported for the volume of the metal bar shown below? (b) If the mass of the bar is 104.7 g, how many significant figures should be reported when its density is calculated using the calculated volume? [Section 1.5]

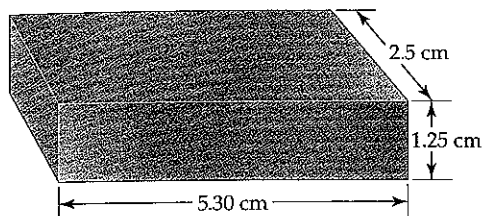

- 1.9 When you convert units, how do you decide which part of the conversion factor is in the numerator and which is in the denominator? [Section 1.6]
- 1.10 Draw a logic map indicating the steps you would take to convert miles per hour to kilometers per second. Write down the conversion factor for each step, as done in the diagram on page 26. [Section 1.6]

EXERCISES

Classification and Properties of Matter

The following exercises are divided into sections that deal with specific topics in the chapter. These exercises are grouped in pairs, with the answer given in the back of the book to the odd-numbered exercise, as indicated by the red exercise number. Those exercises whose number appears in brackets are more challenging than the nonbracketed exercises.

- 1.11 Classify each of the following as a pure substance or a mixture. If a mixture, indicate whether it is homogeneous or heterogeneous: (a) rice pudding, (b) seawater, (c) magnesium, (d) gasoline.
- 1.12 Classify each of the following as a pure substance or a mixture. If a mixture, indicate whether it is homogeneous or heterogeneous: (a) air, (b) tomato juice, (c) iodine crystals, (d) sand.
- 1.13 Give the chemical symbol or name for the following elements, as appropriate: (a) sulfur, (b) magnesium, (c) potassium, (d) chlorine, (e) copper, (f) F, (g) Ni, (h) Na, (i) Al, (j) Si.
- 1.14 Give the chemical symbol or name for each of the following elements, as appropriate: (a) carbon, (b) nitrogen, (c) bromine, (d) zinc, (e) iron, (f) P, (g) Ca, (h) He, (i) Pb, (j) Ag.
- 1.15 A solid white substance A is heated strongly in the absence of air. It decomposes to form a new white substance B and a gas C. The gas has exactly the same properties as the product obtained when carbon is burned in an excess of oxygen. Based on these observations, can we determine whether solids A and B and the gas C are elements or compounds? Explain your conclusions for each substance.
- 1.16 In 1807 the English chemist Humphry Davy passed an electric current through molten potassium hydroxide and isolated a bright, shiny reactive substance. He claimed the discovery of a new element, which he named potassium. In those days, before the advent of modern instruments, what was the basis on which one could claim that a substance was an element?

- 1.17 In the process of attempting to characterize a substance, a chemist makes the following observations: The substance is a silvery white, lustrous metal. It melts at 649 °C and boils at 1105 °C. Its density at 20 °C is 1.738 g/cm³. The substance burns in air, producing an intense white light. It reacts with chlorine to give a brittle white solid. The substance can be pounded into thin sheets or drawn into wires. It is a good conductor of electricity. Which of these characteristics are physical properties, and which are chemical properties?
- 1.18 Read the following description of the element zinc, and indicate which are physical properties and which are chemical properties. Zinc is a silver-gray-colored metal that melts at 420 °C. When zinc granules are added to dilute sulfuric acid, hydrogen is given off and the metal dissolves. Zinc has a hardness on the Mohs scale of 2.5 and a density of 7.13 g/cm³ at 25 °C. It reacts slowly with oxygen gas at elevated temperatures to form zinc oxide, ZnO.
- 1.19 Label each of the following as either a physical process or a chemical process: (a) corrosion of aluminum metal, (b) melting of ice, (c) pulverizing an aspirin, (d) digesting a candy bar, (e) explosion of nitroglycerin.
- 1.20 A match is lit and held under a cold piece of metal. The following observations are made: (a) The match burns, (b) The metal gets warmer, (c) Water condenses on the metal, (d) Soot (carbon) is deposited on the metal. Which of these occurrences are due to physical changes and which are due to chemical changes?
- 1.21 Suggest a method of separating each of the following mixtures into two components: (a) sugar and sand, (b) iron and sulfur.
- 1.22 A beaker contains a clear, colorless liquid. If it is water, how could you determine whether it contained dissolved table salt? Do *not* taste it!

Units and Measurement

- 1.23 What exponential notation do the following abbreviations represent: (a) d, (b) c, (c) f, (d) μ , (e) M, (f) k, (g) n, (h) m, (i) p?
- 1.24 Use appropriate metric prefixes to write the following measurements without use of exponents:
 (a) 6.35×10^{-2} L, (b) 6.5×10^{-6} s, (c) 9.5×10^{-4} m,
 (d) 4.23×10^{-9} m³, (e) 12.5×10^{-8} kg, (f) 3.5×10^{-10} g,
 (g) 6.54×10^9 fs.
- 1.25 Make the following conversions: (a) 62 °F to °C, (b) 216.7 °C to °F, (c) 233 °C to K, (d) 315 K to °F, (e) 2500 °F to K.
- 1.26 (a) The temperature on a warm summer day is 87 °F. What is the temperature in °C? (b) Many scientific data are reported at 25 °C. What is this temperature in kelvins and in degrees Fahrenheit? (c) Suppose that a recipe calls for an oven temperature of 175 °F. Convert this temperature to degrees Celsius and to kelvins. (d) The melting point of sodium bromide (a salt) is 755 °C. Calculate this temperature in °F and in kelvins. (e) Neon, a gaseous element at room temperature, is used to make electronic signs. Neon has a melting point of -248.6 °C and a boiling point of -246.1 °C. Convert these temperatures to kelvins.
- 1.27 (a) A sample of carbon tetrachloride, a liquid once used in dry cleaning, has a mass of 39.73 g and a volume of 25.0 mL at 25 °C. What is its density at this temperature? Will carbon tetrachloride float on water? (Materials that are less dense than water will float.) (b) The density of platinum is 21.45 g/cm³ at 20 °C. Calculate the mass of 75.00 cm³ of platinum at this temperature. (c) The density of magnesium is 1.738 g/cm³ at 20 °C. What is the volume of 87.50 g of this metal at this temperature?
- 1.28 (a) A cube of osmium metal 1.500 cm on a side has a mass of 76.31 g at 25 °C. What is its density in g/cm³ at this temperature? (b) The density of titanium metal is 4.51 g/cm³ at 25 °C. What mass of titanium displaces 125.0 mL of water at 25 °C? (c) The density of benzene at 15 °C is 0.8787 g/mL. Calculate the mass of 0.1500 L of benzene at this temperature.
- 1.29 (a) To identify a liquid substance, a student determined its density. Using a graduated cylinder, she measured out a 45-mL sample of the substance. She then measured the mass of the sample, finding that it weighed 38.5 g. She knew that the substance had to be either isopropyl alcohol (density 0.785 g/mL) or toluene (density 0.866 g/mL). What are the calculated density and the probable identity of the substance? (b) An experiment requires 45.0 g of ethylene glycol, a liquid whose density is 1.114 g/mL. Rather than weigh the sample on a balance, a chemist chooses to dispense the liquid using a graduated cylinder. What volume of the liquid should he use? (c) A cubic piece of metal measures 5.00 cm on each edge. If the metal is nickel, whose density is 8.90 g/cm³, what is the mass of the cube?
- 1.30 (a) After the label fell off a bottle containing a clear liquid believed to be benzene, a chemist measured the density of the liquid to verify its identity. A 25.0-mL portion of the liquid had a mass of 21.95 g. A chemistry handbook lists the density of benzene at 15 °C as 0.8787 g/mL. Is the calculated density in agreement with the tabulated value? (b) An experiment requires 15.0 g of cyclohexane, whose density at 25 °C is 0.7781 g/mL. What volume of cyclohexane should be used? (c) A spherical ball of lead has a diameter of 5.0 cm. What is the mass of the sphere if lead has a density of 11.34 g/cm³? (The volume of a sphere is $(\frac{4}{3})\pi r^3$ where r is the radius.)
- 1.31 Gold can be hammered into extremely thin sheets called gold leaf. If a 200-mg piece of gold (density = 19.32 g/cm³) is hammered into a sheet measuring 2.4 × 1.0 ft, what is the average thickness of the sheet in meters? How might the thickness be expressed without exponential notation, using an appropriate metric prefix?
- 1.32 A cylindrical rod formed from silicon is 16.8 cm long and has a mass of 2.17 kg. The density of silicon is 2.33 g/cm³. What is the diameter of the cylinder? (The volume of a cylinder is given by $\pi r^2 h$, where r is the radius, and h is its length.)

Uncertainty in Measurement

- 1.33 Indicate which of the following are exact numbers: (a) the mass of a paper clip, (b) the surface area of a dime, (c) the number of inches in a mile, (d) the number of ounces in a pound, (e) the number of microseconds in a week, (f) the number of pages in this book.
- 1.34 Indicate which of the following are exact numbers: (a) the mass of a 32-oz can of coffee, (b) the number of students in your chemistry class, (c) the temperature of the surface of the sun, (d) the mass of a postage stamp, (e) the number of milliliters in a cubic meter of water, (f) the average height of students in your school.
- 1.35 What is the number of significant figures in each of the following measured quantities? (a) 358 kg, (b) 0.054 s, (c) 6.3050 cm, (d) 0.0105 L, (e) 7.0500×10^{-3} m³.
- 1.36 Indicate the number of significant figures in each of the following measured quantities: (a) 3.774 km, (b) 205 m², (c) 1.700 cm, (d) 350.00 K, (e) 307.080 g.
- 1.37 Round each of the following numbers to four significant figures, and express the result in standard exponential notation: (a) 102.53070, (b) 656,980, (c) 0.008543210, (d) 0.000257870, (e) -0.0357202.
- 1.38 (a) The diameter of Earth at the equator is 7926.381 mi. Round this number to three significant figures, and express it in standard exponential notation. (b) The circumference of Earth through the poles is 40,008 km. Round this number to four significant figures, and express it in standard exponential notation.

- 1.39 Carry out the following operations, and express the answers with the appropriate number of significant figures.
- $12.0550 + 9.05$
 - $257.2 - 19.789$
 - $(6.21 \times 10^3)(0.1050)$
 - $0.0577/0.753$

- 1.40 Carry out the following operations, and express the answer with the appropriate number of significant figures.
- $320.5 - (6104.5/2.3)$
 - $[(285.3 \times 10^5) - (1.200 \times 10^3)] \times 2.8954$
 - $(0.0045 \times 20,000.0) + (2813 \times 12)$
 - $863 \times [1255 - (3.45 \times 108)]$

Dimensional Analysis

- 1.41 Using your knowledge of metric units, English units, and the information on the back inside cover, write down the conversion factors needed to convert (a) mm to nm, (b) mg to kg, (c) km to ft, (d) in.^3 to cm^3 .

- 1.42 Using your knowledge of metric units, English units, and the information on the back inside cover, write down the conversion factors needed to convert (a) μm to mm, (b) ms to ns, (c) mi to km, (d) ft^3 to L.

- 1.43 Perform the following conversions: (a) 0.076 L to mL, (b) 5.0×10^{-8} m to nm, (c) 6.88×10^5 ns to s, (d) 0.50 lb to g, (e) 1.55 kg/m^3 to g/L, (f) 5.850 gal/hr to L/s.

- 1.44 (a) The speed of light in a vacuum is 2.998×10^8 m/s. Calculate its speed in km/hr. (b) The Sears Tower in Chicago is 1454 ft tall. Calculate its height in meters. (c) The Vehicle Assembly Building at the Kennedy Space Center in Florida has a volume of $3,666,500 \text{ m}^3$. Convert this volume to liters, and express the result in standard exponential notation. (d) An individual suffering from a high cholesterol level in her blood has 232 mg of cholesterol per 100 mL of blood. If the total blood volume of the individual is 5.2 L, how many grams of total blood cholesterol does the individual's body contain?

- 1.45 Perform the following conversions: (a) 5.00 days to s, (b) 0.0550 mi to m, (c) \$1.89/gal to dollars per liter, (d) 0.510 in./ms to km/hr, (e) 22.50 gal/min to L/s, (f) 0.02500 ft^3 to cm^3 .

- 1.46 Carry out the following conversions: (a) 0.105 in. to mm, (b) 0.650 qt to mL, (c) $8.75 \mu\text{m/s}$ to km/hr, (d) 1.955 m^3 to yd^3 , (e) \$3.99/lb to dollars per kg, (f) 8.75 lb/ft^3 to g/mL.

- 1.47 (a) How many liters of wine can be held in a wine barrel whose capacity is 31 gal? (b) The recommended adult dose of Elixophyllin[®], a drug used to treat asthma, is 6 mg/kg of body mass. Calculate the dose in milligrams for a 150-lb person. (c) If an automobile is able to travel 254 mi on 11.2 gal of gasoline, what is the gas mileage in km/L? (d) A pound of coffee beans yields 50 cups of coffee (4 cups = 1 qt). How many milliliters of coffee can be obtained from 1 g of coffee beans?

- 1.48 (a) If an electric car is capable of going 225 km on a single charge, how many charges will it need to travel from Boston, Massachusetts, to Miami, Florida, a distance of 1486 mi, assuming that the trip begins with a full charge? (b) If a migrating loon flies at an average speed of 14 m/s, what is its average speed in mi/hr? (c) What is the engine piston displacement in liters of an engine whose displacement is listed as 450 in.^3 ? (d) In March 1989 the *Exxon Valdez* ran aground and spilled 240,000 barrels of crude petroleum off the coast of Alaska. One barrel of petroleum is equal to 42 gal. How many liters of petroleum were spilled?

- 1.49 The density of air at ordinary atmospheric pressure and 25 °C is 1.19 g/L. What is the mass, in kilograms, of the air in a room that measures $12.5 \times 15.5 \times 8.0$ ft?

- 1.50 The concentration of carbon monoxide in an urban apartment is $48 \mu\text{g/m}^3$. What mass of carbon monoxide in grams is present in a room measuring $9.0 \times 14.5 \times 18.8$ ft?

- 1.51 By using estimation techniques, arrange these items in order from shortest to longest: a 57-cm length of string, a 14-in. long shoe, and a 1.1-m length of pipe.

- 1.52 By using estimation techniques, determine which of the following is the heaviest and which is the lightest: a 5-lb bag of potatoes, a 5-kg bag of sugar, or 1 gal of water (density = 1.0 g/mL).

- 1.53 The Morgan silver dollar has a mass of 26.73 g. By law, it was required to contain 90% silver, with the remainder being copper. (a) When the coin was minted in the late 1800s, silver was worth \$1.18 per troy ounce (31.1 g). At this price, what is the value of the silver in the silver dollar? (b) Today, silver sells for about \$13.25 per troy ounce. How many Morgan silver dollars are required to obtain \$25.00 worth of pure silver?

- 1.54 A copper refinery produces a copper ingot weighing 150 lb. If the copper is drawn into wire whose diameter is 8.25 mm, how many feet of copper can be obtained from the ingot? The density of copper is 8.94 g/cm^3 (Assume that the wire is a cylinder whose volume is $V = \pi r^2 h$, where r is its radius and h is its height or length.)

ADDITIONAL EXERCISES

The exercises in this section are not divided by category, although they are roughly in the order of the topics in the chapter. They are not paired.

- 1.55 What is meant by the terms composition and structure when referring to matter?

- 1.56 (a) Classify each of the following as a pure substance, a solution, or a heterogeneous mixture: a gold coin, a cup

of coffee, a wood plank. (b) What ambiguities are there in answering part (a) from the descriptions given?

- 1.57 (a) What is the difference between a hypothesis and a theory? (b) Explain the difference between a theory and a scientific law. Which addresses how matter behaves, and which addresses why it behaves that way?

- 1.58 A sample of ascorbic acid (vitamin C) is synthesized in the laboratory. It contains 1.50 g of carbon and 2.00 g of

oxygen. Another sample of ascorbic acid isolated from citrus fruits contains 6.35 g of carbon. How many grams of oxygen does it contain? Which law are you assuming in answering this question?

- 1.59 Two students determine the percentage of lead in a sample as a laboratory exercise. The true percentage is 22.52%. The students' results for three determinations are as follows:
- 22.52, 22.48, 22.54
 - 22.64, 22.58, 22.62
- (a) Calculate the average percentage for each set of data, and tell which set is the more accurate based on the average. (b) Precision can be judged by examining the average of the deviations from the average value for that data set. (Calculate the average value for each data set, then calculate the average value of the absolute deviations of each measurement from the average.) Which set is more precise?
- 1.60 Is the use of significant figures in each of the following statements appropriate? Why or why not? (a) The 2005 circulation of *National Geographic* was 7,812,564. (b) On July 1, 2005, the population of Cook County, Illinois, was 5,303,683. (c) In the United States, 0.621% of the population has the surname Brown.
- 1.61 What type of quantity (for example, length, volume, density) do the following units indicate: (a) mL, (b) cm^2 , (c) mm^3 , (d) mg/L, (e) ps, (f) nm, (g) K?
- 1.62 Give the derived SI units for each of the following quantities in base SI units: (a) acceleration = distance/time²; (b) force = mass \times acceleration; (c) work = force \times distance; (d) pressure = force/area; (e) power = work/time.
- 1.63 The distance from Earth to the Moon is approximately 240,000 mi. (a) What is this distance in meters? (b) The peregrine falcon has been measured as traveling up to 350 km/hr in a dive. If this falcon could fly to the Moon at this speed, how many seconds would it take?
- 1.64 The US quarter has a mass of 5.67 g and is approximately 1.55 mm thick. (a) How many quarters would have to be stacked to reach 575 ft, the height of the Washington Monument? (b) How much would this stack weigh? (c) How much money would this stack contain? (d) At the beginning of 2007, the national debt was \$8.7 trillion. How many stacks like the one described would be necessary to pay off this debt?
- 1.65 In the United States, water used for irrigation is measured in acre-feet. An acre-foot of water covers an acre to a depth of exactly 1 ft. An acre is 4840 yd². An acre-foot is enough water to supply two typical households for 1.00 yr. (a) If desalinated water costs \$1950 per acre-foot, how much does desalinated water cost per liter? (b) How much would it cost one household per day if it were the only source of water?
- 1.66 Suppose you decide to define your own temperature scale using the freezing point (-11.5°C) and boiling point (197.6°C) of ethylene glycol. If you set the freezing point as 0°G and the boiling point as 100°G , what is the freezing point of water on this new scale?
- 1.67 The liquid substances mercury (density = 13.5 g/mL), water (1.00 g/mL), and cyclohexane (0.778 g/mL) do not form a solution when mixed, but separate in distinct layers. Sketch how the liquids would position themselves in a test tube.
- 1.68 Small spheres of equal mass are made of lead (density = 11.3 g/cm^3), silver (10.5 g/cm^3), and aluminum (2.70 g/cm^3). Without doing a calculation, list the spheres in order from the smallest to the largest.
- 1.69 Water has a density of 0.997 g/cm^3 at 25°C ; ice has a density of 0.917 g/cm^3 at -10°C . (a) If a soft-drink bottle whose volume is 1.50 L is completely filled with water and then frozen to -10°C , what volume does the ice occupy? (b) Can the ice be contained within the bottle?
- 1.70 A 32.65-g sample of a solid is placed in a flask. Toluene, in which the solid is insoluble, is added to the flask so that the total volume of solid and liquid together is 50.00 mL. The solid and toluene together weigh 58.58 g. The density of toluene at the temperature of the experiment is 0.864 g/mL . What is the density of the solid?
- 1.71 (a) You are given a bottle that contains 4.59 cm^3 of a metallic solid. The total mass of the bottle and solid is 35.66 g. The empty bottle weighs 14.23 g. What is the density of the solid? (b) Mercury is traded by the "flask," a unit that has a mass of 34.5 kg. What is the volume of a flask of mercury if the density of mercury is 13.5 g/mL ? (c) A thief plans to steal a gold sphere with a radius of 28.9 cm from a museum. If the gold has a density of 19.3 g/cm^3 what is the mass of the sphere? [The volume of a sphere is $V = (4/3)\pi r^3$.] Is he likely to be able to walk off with it unassisted?
- 1.72 Automobile batteries contain sulfuric acid, which is commonly referred to as "battery acid." Calculate the number of grams of sulfuric acid in 0.500 L of battery acid if the solution has a density of 1.28 g/mL and is 38.1% sulfuric acid by mass.
- 1.73 A 40-lb container of peat moss measures $14 \times 20 \times 30$ in. A 40-lb container of topsoil has a volume of 1.9 gal. (a) Calculate the average densities of peat moss and topsoil in units of g/cm^3 . Would it be correct to say that peat moss is "lighter" than topsoil? Explain. (b) How many bags of the peat moss are needed to cover an area measuring 10. ft by 20. ft to a depth of 2.0 in.?
- 1.74 A coin dealer offers to sell you an ancient gold coin that is 2.2 cm in diameter and 3.0 mm in thickness. (a) The density of gold is 19.3 g/cm^3 . How much should the coin weigh if it is pure gold? (b) If gold sells for \$640 per troy ounce, how much is the gold content worth? (1 troy ounce = 31.1 g).
- 1.75 A package of aluminum foil contains 50 ft² of foil, which weighs approximately 8.0 oz. Aluminum has a density of 2.70 g/cm^3 . What is the approximate thickness of the foil in millimeters?
- 1.76 A 15.0-cm long cylindrical glass tube, sealed at one end, is filled with ethanol. The mass of ethanol needed to fill the tube is found to be 11.86 g. The density of ethanol is 0.789 g/mL . Calculate the inner diameter of the tube in centimeters.
- 1.77 Gold is alloyed (mixed) with other metals to increase its hardness in making jewelry. (a) Consider a piece of gold jewelry that weighs 9.85 g and has a volume of

0.675 cm^3 . The jewelry contains only gold and silver, which have densities of 19.3 g/cm^3 and 10.5 g/cm^3 , respectively. If the total volume of the jewelry is the sum of the volumes of the gold and silver that it contains, calculate the percentage of gold (by mass) in the jewelry. (b) The relative amount of gold in an alloy is commonly expressed in units of karats. Pure gold is 24-karat, and the percentage of gold in an alloy is given as a percentage of this value. For example, an alloy that is 50% gold is 12-karat. State the purity of the gold jewelry in karats.

- 1.78 Suppose you are given a sample of a homogeneous liquid. What would you do to determine whether it is a solution or a pure substance?
- 1.79 Chromatography (Figure 1.14) is a simple, but reliable, method for separating a mixture into its constituent substances. Suppose you are using chromatography to separate a mixture of two substances. How would you know whether the separation is successful? Can you propose a means of quantifying how good or how poor the separation is?
- 1.80 You are assigned the task of separating a desired granular material, with a density of 3.62 g/cm^3 , from an undesired granular material that has a density of 2.04 g/cm^3 . You want to do this by shaking the mixture in a liquid in which the heavier material will fall to the bottom and the lighter material will float. A solid will float on any liquid that is more dense. Using the internet or a handbook of chemistry, find the densities of the following substances: carbon tetrachloride, hexane, benzene, and methylene iodide. Which of these liquids will serve your purpose, assuming no chemical interaction between the liquid and the solids?
- 1.81 In 2006, Professor Galen Suppes, from the University of Missouri-Columbia, was awarded a Presidential Green Challenge Award for his system of converting glycerin, $\text{C}_3\text{H}_5(\text{OH})_3$, a by-product of biodiesel production, to propylene glycol, $\text{C}_3\text{H}_6(\text{OH})_2$. Propylene glycol pro-

duced in this way will be cheap enough to replace the more toxic ethylene glycol that is the primary ingredient in automobile antifreeze. (a) If 50.0 mL of propylene glycol has a mass of 51.80 g, what is its density? (b) To obtain the same antifreeze protection requires 76 g of propylene glycol to replace each 62 g of ethylene glycol. Calculate the mass of propylene glycol required to replace 1.00 gal of ethylene glycol. The density of ethylene glycol is 1.12 g/mL . (c) Calculate the volume of propylene glycol, in gallons, needed to produce the same antifreeze protection as 1.00 gallon of ethylene glycol.

- 1.82 The concepts of accuracy and precision are not always easy to grasp. Here are two sets of studies: (a) The mass of a secondary weight standard is determined by weighing it on a very precise balance under carefully controlled laboratory conditions. The average of 18 different weight measurements is taken as the weight of the standard. (b) A group of 10,000 males between the ages of 50 and 55 is surveyed to ascertain a relationship between calorie intake and blood cholesterol level. The survey questionnaire is quite detailed, asking the respondents about what they eat, smoking and drinking habits, and so on. The results are reported as showing that for men of comparable lifestyles, there is a 40% chance of the blood cholesterol level being above 230 for those who consume more than 40 calories per gram of body weight per day, as compared with those who consume fewer than 30 calories per gram of body weight per day.

Discuss and compare these two studies in terms of the precision and accuracy of the result in each case. How do the two studies differ in nature in ways that affect the accuracy and precision of the results? What makes for high precision and accuracy in any given study? In each of these studies, what factors might not be controlled that could affect the accuracy and precision? What steps can be taken generally to attain higher precision and accuracy?